



Original instructions in English

OPERATING INSTRUCTIONS BS-110

VERSION 1.7





Inspection comments

Inspection before initial operation on:	_____
By:	_____
Date of initial operation:	_____
Serial number & Year of manufacture:	_____

Recurring inspections / maintenance log

Date / Hour counter	Findings	Repairs / Cleaning	Test on	By*

*Competent person



Table of contents

Inspection comments	2
1 Introduction	4
2 Machine description	4
3 Safety	5
3.1 Work area safety	5
3.2 Electrical safety	5
3.3 Personal safety	5
3.4 Machine safety	6
3.5 Maintenance safety	6
3.6 Transport safety	6
3.7 Signs on the machine	8
4 Initial operation	9
4.1 Checkpoints:	9
Electrical safety	
Machine safety	
4.2 Drive wheel engaging and disengaging	9
4.3 Transport wheel	10
5 Operation	11
5.1 Electric controls	11
5.2 Height adjusting steering handle	11
5.3 Narrow mode steering handle	12
5.4 Blades	12
Blade choice	12
Blade versions	13
Blade changing	14
Blade sharpening	15
5.5 Start up machine	15
5.6 Types of tear outs	16
5.7 Ditching	17
5.8 Removing weights	18
5.9 Angle adjustment plates 4° and 8°	19
6 Maintenance	20
6.1 Wheel scraper plates	21
6.2 Replacing shock absorbers	21
6.3 Frequency inverter	22
6.4 Wheel bearings	23
7 Technical data	26
7.1 Sound and vibration data	27
7.2 Extension cables	28
Contact	



1. Introduction

Before use, operators must be provided with information, instruction and training for the use of the machine and the substances for which it is to be used, including the safe method of removal and disposal of the material collected. All persons who are working with or maintaining this machine must read the manual carefully and understand it fully. In case you sell the unit, hand it on to the next owner. Keep this manual always with the machine, to enable it to be referred to at any time. Any other work not covered by this operating manual must not be carried out.

This machine is designed for industrial use by professionals. **Only authorized and trained personnel may operate this machine.** This machine is not intended for use by persons (including children) with reduced physical, sensory or mental capabilities, or lack of experience and knowledge. **Blastrac BV** offers a course on the use of the machine in order to make the operating and maintenance personnel familiar with all elements of the machine. Always use common sense when working with machines.

2. Machine description

The Blastrac BS-110 stripper is ideally suited for small and medium sized applications. The machine has a strong electric drive system which is very easy to operate. The machine has forward, backward and speed control functions.

Main assets of BS-110:

- Electrical driven machine with two electrical motors.
- Forward and backward driving function.
- Standard speed control.
- User and environmentally friendly; very low noise level, easy to operate and low vibrations.
- Very high output.
- Adjustable handle position.
- Shock absorbing handles.
- Wheel scrapers as standard.
- Small and compact equipment, very easy for transportation.
- Weights can easily be removed.
- Heavy duty equipment, which is almost maintenance free.
- Standard transport wheel on the machine.
- Lifting handle in front of machine and lifting eye in middle position of machine.

1	Tool holder
2	M12 nuts, unscrew to remove weights
3	Transport wheel
4	Function selection switch
5	Speed control
6	Clamp lever adjustable steer handle
7	Shock absorbing handle
8	Mounting hole handle narrow position
9	Drive switch lever for narrow mode
10	Lifting eye
11	Drive wheel with quick release pin
12	Hole for pin for handle in transport position

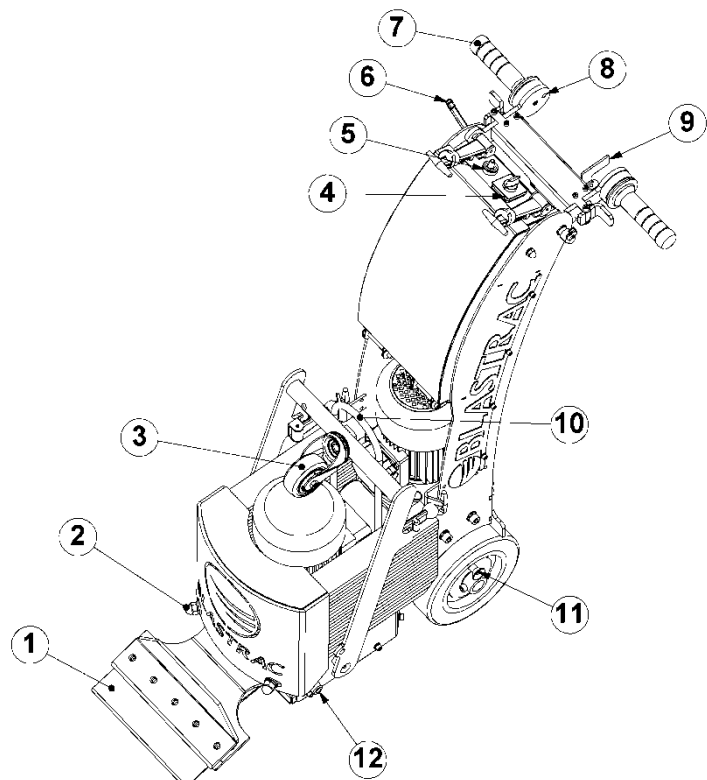



3. General Safety Rules

Warning!

Read all safety warnings and all instructions. Failure to follow the warnings and instructions may result in electric shock, fire, explosions and / or serious injuries.



Only authorized and trained personnel may operate this machine. This machine is not intended for use by persons (including children) with reduced physical, sensory or mental capabilities, or lack of experience and knowledge. Always use common sense when working with machines.

It is the responsibility of the user to analyse the surface to be treated. The surface may not contain any substances which could pose a fire-, explosion- or health risk when treated. The user should make a risk assessment on the basis of the information obtained about the surface to be treated and take proper precautions for the work to be performed.

In case of any inappropriate usage, improper operation or repair, the producer shall be exempt from liability.

3.1 Work area safety

- a) Do not use the machine in rain, damp or wet locations.
- b) **Avoid dangerous environments:** do not work in the presence of explosive atmospheres, in the presence of flammable liquids, gases or dust. Remove materials or debris that may be ignited by sparks.
- c) Make sure there is enough ambient light on the work area. Cluttered or dark areas invite accidents.
- d) Keep children and bystanders away while operating the machine. They are likely not to foresee the potential dangers of the machine. Distractions could cause you to lose control of the machine.
- e) Secure the work area around the machine in public areas providing an adequate safety distance from the machine. Use a red and white safety chain and danger sign to enclose the work area if necessary.
- f) Persons who are not operating the machine must not be permitted to stay in the surrounding area of at least 5 meter from the machine.
- g) Never use the machine when the surface is not clear and if there is a risk of stumbling or tripping.
- h) Make sure that there is nothing standing or situated on the surface to be treated.
- i) Remove reinforcing steel or other objects protruding from the surface in order to prevent damage to the machine.
- j) **Warning! Make sure that the surface to be treated does not contain dangerous materials such as:**
 - combustible or explosive dusts or substances.
 - carcinogenic or pathogenic substances.

3.2 Electrical safety

- a) Use only extension cables for extending the main cable that are sized and marked in accordance with the overall power consumption of the machine. Do not use damaged extension cables.
- b) Electrical cables must be rolled entirely off of the reels.
- c) Any damage to the electric cables and/or electrical components is not permitted.
- d) The voltage on the identification plate must comply with the power supply.
- e) Use an electrical power supply connection with earth connection and earth leakage circuit breaker.
- f) **Keep the machine original; The machine is always equipped with an earthed connection, do not change this** and always use earthed cables with an earthed plug.
- g) Inspect and test the electrical components regularly. The electrical components have to satisfy with the requirements set out in the harmonised norm EN60204-1.
- h) Always call a skilled electrician or your distributor when you have questions about the safety of the electrical components.
- i) Work on electrical equipment or operating materials may only be undertaken by a skilled electrician or by trained persons under the guidance and supervision of a skilled electrician as well as in accordance with the electrical engineering regulations.
- j) Do not abuse the power cord. Never use the cord for carrying, pulling or unplugging the machine. Keep cord away from heat, oil, sharp edges or moving parts. Damaged or entangled cords increase the risk of electric shock.
- k) Be careful with water on the treated surface. Electrical cables must not come into contact with water.
- l) The main power switch on the machine must be in the "0" position before connecting to the power supply.
- m) During a long standstill of the machine, pull out the main plug.

3.3 Personal safety

- a) **Always wear Personal Protective Equipment while working with or around the machine!**
 - Dust mask class FFP2 or higher
 - Hearing protection
 - Safety glasses with lateral protection
 - Protecting, cut-resistant & vibration dampening gloves
 - Safety shoes.



- b) Always wear close-fitting protective clothing. Do not wear loose clothing or jewellery. Keep your hair, clothing and gloves away from moving parts.
- c) Stay alert, watch what you are doing and use common sense when operating the machine.
- d) Always seek professional medical attention immediately in case of injury.
- e) All persons surrounding the machine should wear Personal Protective Equipment.

3.4 Machine safety general

- a) Safety functions and operating functions must work correct.
- b) No loose bolts, nuts or other fasteners are permitted.
- c) Never operate machine without the guards and/or safety devices in place.
- d) Never change anything on the safety devices on the machine!
- e) The machine, specially the handle grips must be free of fats/oils and have to be dry.
- f) Do not **open** or **remove protective guards** while driving gears are running.
- g) Do not pull out the power supply cable by the wire, but by the connector.
- h) All repair work has to be done by qualified Blastrac personnel, this guarantees a safe and reliable machine.
- i) Always use original Blastrac spare parts and cutting blades, this will ensure the best performance.
- j) Only original parts meet the factory specifications and quality. Otherwise Blastrac BV cannot guarantee the safety of the machine. The part numbers can be found in the Service Manual.
- k) If safety-critical changes occur to the machine or its working method, the machine must be shut down immediately! The cause of the fault must be established, and rectified.
- l) In the event of operational malfunctions the machine must be shut down immediately and secured!
- m) Do not stand on the machine. Do not add extra weight on the machine.
- n) Do not place anything on the vibration motor. Make sure that the motor has enough airflow to cool.

3.5 Maintenance safety

- a) **Pull out the main plug before starting inspections and repairing on the machine.**
- b) Wait for standstill of all drives before any inspections, adjustments and/or maintenance work is started.
- c) Block machine in stable position before doing any maintenance work.
- d) Failures due to inadequate or incorrect maintenance may generate very **high repair costs** and long standstill periods of the machine. **Regular** maintenance therefore is imperative.
- e) Operational safety and service life of the machine depends, among other things, on proper maintenance.
- f) Prevent premature wear by keeping the machine as dust free as possible. Clean the machine for this reason regularly with a dust collector and non-aggressive materials. Never use a high pressure water cleaner to clean the machine.
- g) It is advisable to stock all spare parts or wear parts that cannot be supplied quickly. As a rule, production standstill periods are more expensive than the cost for the corresponding spare part.
- h) The suitable precautions for maintenance include decontamination before disassembling the machine, adequate filtered ventilation of the exhaust air from the room in which it is disassembled, cleaning of the maintenance area and suitable personal protection equipment.

3.6 Transport safety

- a) Be aware of your surroundings and machine operating level. Do not side hill, do not run on steep incline, this could cause machine to tip over.
- b) The weight of the BS-110 MKIII is 170kg with the weights. Use preferably appropriate appliances as a lift or crane. Use the existing lifting points to lift the machine.
- c) **Never lift the machine with mounted tool! This sharp tool can be very dangerous!**
- d) Chock wheels for transport and keep control handle in neutral position.
- e) Don't leave the machine unsecured on jobsites.
- f) Park the machine always on a flat horizontal and levelled surface.
- g) Store the cleaned and dry machine in a humid free room. Protect the electrical motor from moisture, heat dust and shocks.
- h) Never use the machine for lifting persons or items.
- i) Before every use check the lifting points and welds for: deformation, damages, cracks, corrosion and wear.
- j) When lifting the machine from the ground, always use the lowest lifting speed. The cables must first be tensioned at this speed; they must not be slack when the machine is lifted from the ground.



- k) During hoisting make sure to be at a safe distance from the machine with the most optimal view on the machine and working environment.
- l) Never stand directly below the machine.
- m) When transporting the machine do so in such a manner that damage due to the effects of the use of force or incorrect loading and unloading is avoided.
- n) The lifting point can also be used to fasten the machine on a pallet or during transport.
- o) Never load or unload the machine on a ramp or incline when the wheels are in the disengage mode. Failure to do so could cause machine to runaway, damage to the machine, damage to property or cause serious injury.

Never lift the machine with mounted tool! This sharp tool can be very dangerous!

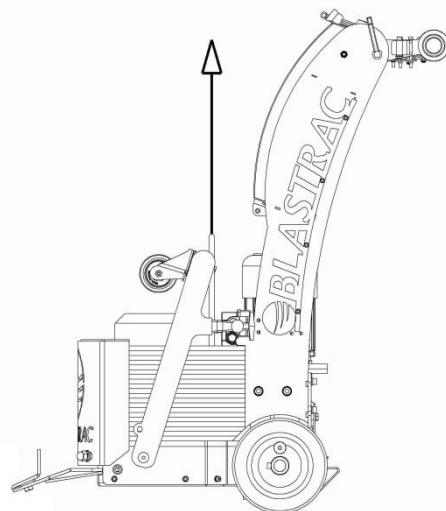
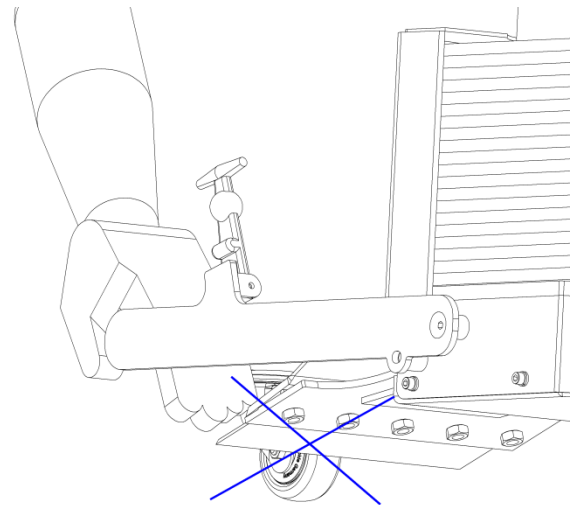
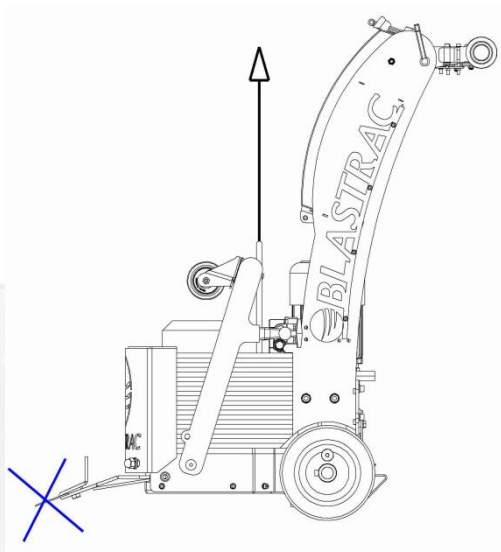

Lift the machine without mounted tool
Make sure the rubber clamps of the transport wheel are fastened.
Only lift the machine on the lifting point.



3.7 Signs on the machine

The following stickers are placed on the machine. Meanings of these symbols are:



! Danger Hazardous voltage in motor even when solid state controller is OFF. Disconnect main power before servicing motor, controller or associated wiring.



Lifting point.



Wear a dust mask class FFP3 or higher.



Hearing protection is obliged.



Safety glasses with lateral protection are obliged.



CE-mark on this machine.



Wear protecting gloves.



Safety shoes obliged.



Consult the manual before operating the machine.

Type plate:

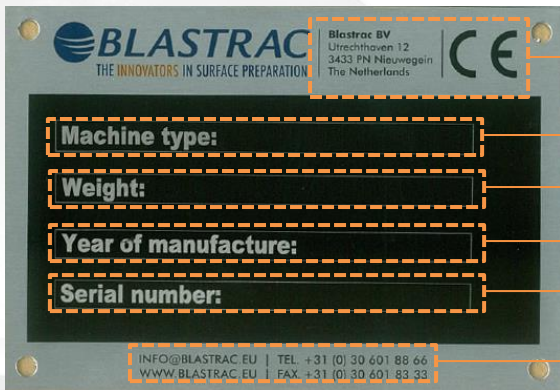

Name, address and CE mark.

The machine type.

The net weight of the machine in kilogram.

The year of manufacture.

The serial number of the machine.

Email address, Website, Telephone & fax number.

EU Declaration of Conformity:





4. Initial operation

Before using the machine it is of great importance to inspect the machine every day. It is not permitted to use the machine if the machine safety is not according the checkpoints below.

4.1 Checkpoints:

Electrical safety

- Use only extension cables for extending the main cable that are sized and marked in accordance with the overall power consumption of the machine.
- Electrical cables must be rolled entirely off of the reels.
- Any damage to electric cables is not permitted.
- Use an electrical power supply connection with earth connection.
- The selection switch of the machine should be put to '0' (OFF) before connecting to the power supply.

Machine safety

Check if:

- The safety functions and operating functions work correct.
- There are not any loose nuts or bolts.
- There are no damages on the electrical components.

4.2 Drive wheel engaging and disengaging

The drive wheels are engaged with quick release pins, remove them for easy transport by hand.

Line up the wheel hub hole and wheel hole to insert the pin as following:

- 1: Lay the machine all the way back on the steering handle. (Picture 1.)
- 2: Rotate the wheel to align the holes. (Picture 2.)
- 3: Insert the quick release pin. (Picture 3.)
- 4: Repeat step 2 and 3 on the other wheel.

Disengage Mode (Picture 2.)

When wheels are in the "disengage mode" The machine can be moved around freely when the machine is NOT under power.

Engage Mode (Picture 3.)

Wheels in the "engage mode" are secured with the quick release pins. This engages the wheels to drive motor to be self-propelled.

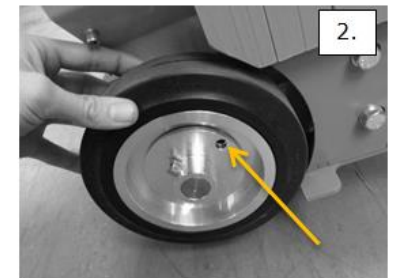
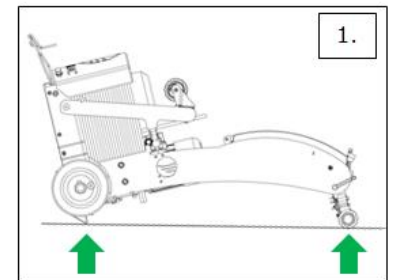

Never load or unload the machine on a ramp or incline when the wheels are in the disengage mode. Failure to do so could cause machine to runaway, damage to the machine, damage to property or cause serious injury.



4.3 Transport wheel

The transport wheel helps to move the machine easily and eliminates damaging the floor.

Disconnect the machine from the power supply.

1: Lay the machine all the way back on the steering handle. (Picture 1.)

2: Make sure the sharp tool is removed!

WARNING!
Remove the blade tool before rotating the transport wheel!
This tool can be very sharp!

Loosen the 2 rubber clamps and rotate the transport wheel forward.

Observe the correct hand position.

Insert the quick release pins on the right side and the left side of the machine.

Remove the 2 quick release pins from the wheels.
 The machine is now ready to be moved around manually.

Be careful! Make sure nobodies feet get under the wheels.
 Wear appropriate safety shoes when you drive the machine to or from the work area.

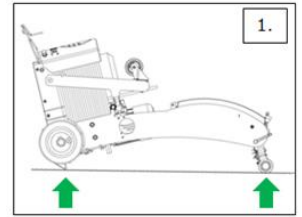

Warning!
 Sharp tool!

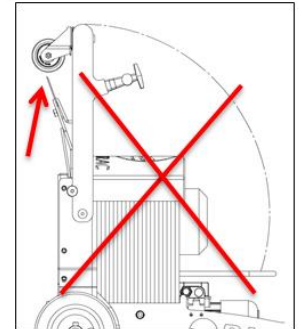

Correct
 hand
 position

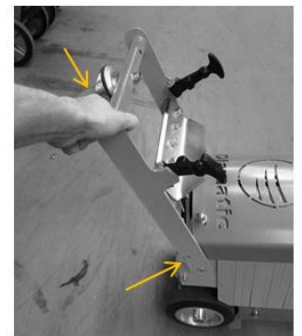

Insert quick
 release pin



5. Operation

5.1 Electric controls

The selection switch (1) is mounted on top of the machine. Switch to 1 to activate the drive motors and the machine is ready to drive using the control levers (3 & 4). The drive speed can be adjusted with the drive speed control (2).

Use the right switch lever (3) to drive forward and the left switch lever (4) to drive backward.

Switch the selection switch to 2 to activate the vibration motor. Selection switch on zero switches off all functions.

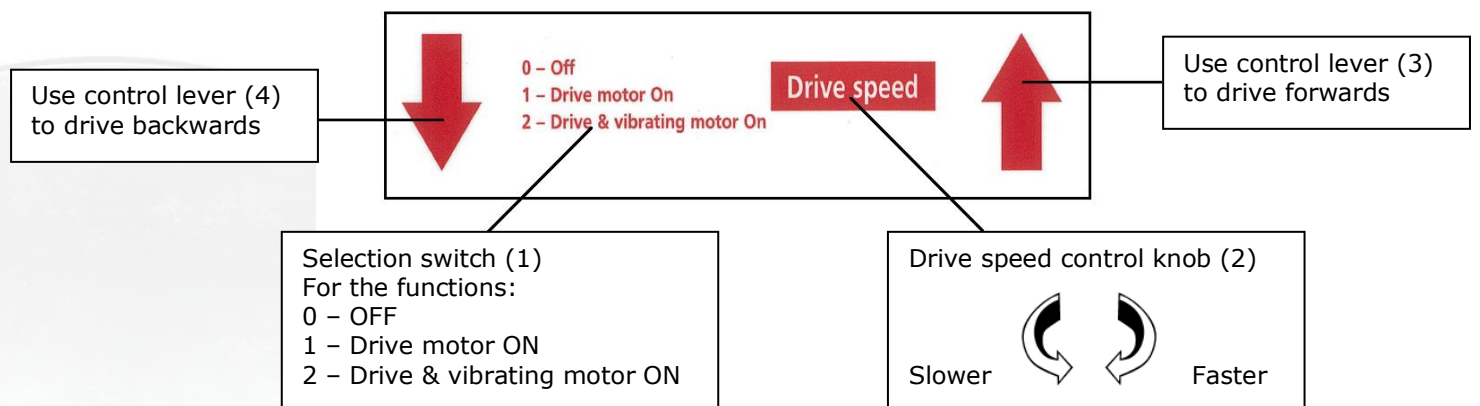
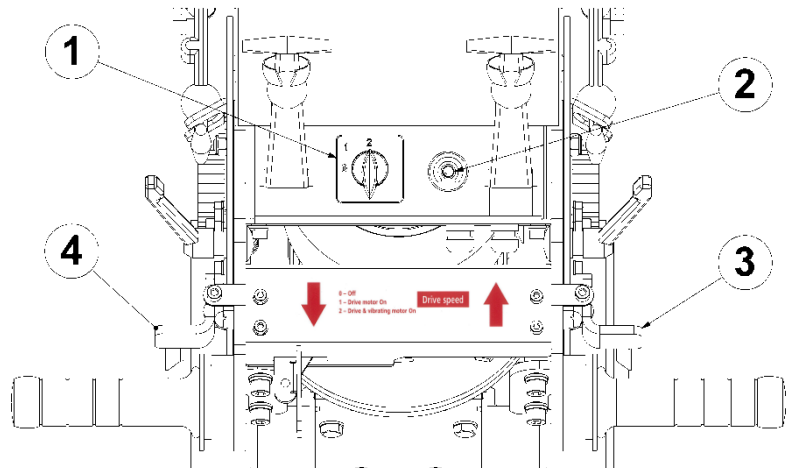

5.2 Height adjustment steering handle

Adjusting the height of the steering handle is possible by loosening the clamp levers (1) to find a comfortable working position.

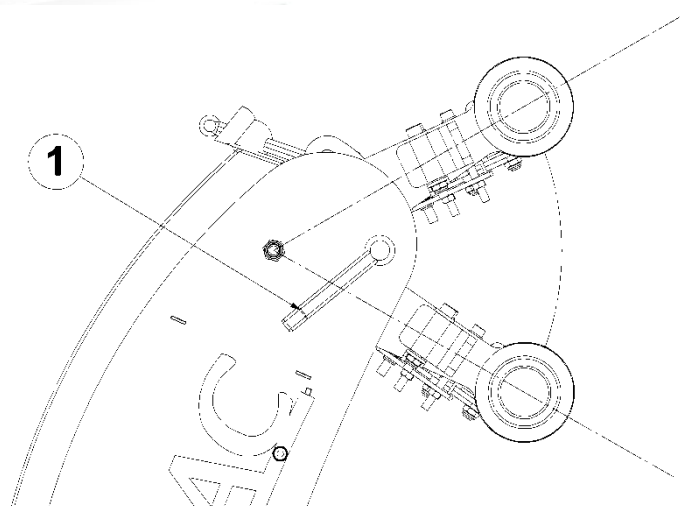



5.3 Narrow mode steering handle

To work as close as possible alongside the wall it is possible to remove the right handle grip. The handle grip (2) can be screwed into the opposite side of the handle. The internal switch (1) lever can be used to switch the drive motor to forwards.

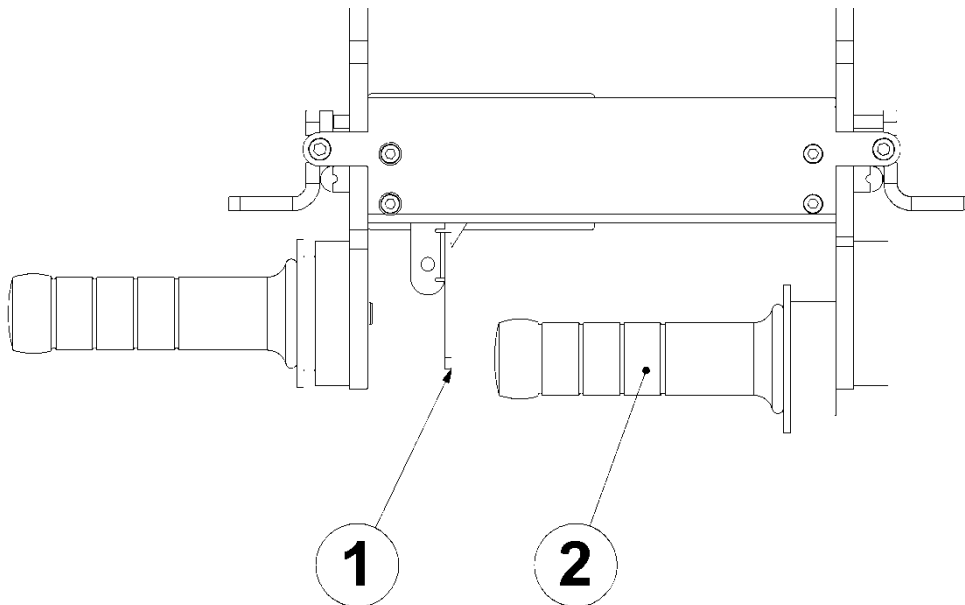

5.4 Blades

Blade choice

Proper blade size and placement, depending on the material and sub-floor type, affects the performance.

- KEEP BLADES SHARP. Dull blades greatly reduce cutting ability. Re-sharpen or replace as needed.
- The harder a job comes up, for best results, use a smaller blade.
- Start with a narrow blade, then increase the blade size to optimize the cutting pass.
- Narrower blades work easier than wider blades, wider is not always better or faster.
- Narrower blades usually clean the floor better.
- Normally the bevel on the blade is up for concrete. Bevel down for wood or soft sub-floors.



- Keep your work area clean and clear of debris.
- After you have removed a portion of material, remove it out of the way. This will give the machine maximum performance and helps to keep the work area safe.
- **Always wear cut-resistant gloves when handling blades.**
- Everyone in the work area should wear eye protection.



Blade versions

Blade #1 (Part No. E09533) - 305 x 76 mm, thickness 1,5 mm
self-scoring blade, bevel up, carpet, soft (PVC, linoleum, rubber)

Blade #2 (Part No. E09510) - 152 x 76 mm, thickness 1,5 mm
tile or linoleum on wood floors, difficult surfaces (ceramic, hardwood, heavy tile, etc.)

Blade #3 (Part No. E09512) - 254 x 76 mm, thickness 1,5 mm
carpet, tile or resilient on wood & concrete floors

Blade #4 (Part No. E09502) - 254 x 76 mm, thickness 2,5 mm
carpet, tile, PVC, Vct, tough coatings, hardwood & cork

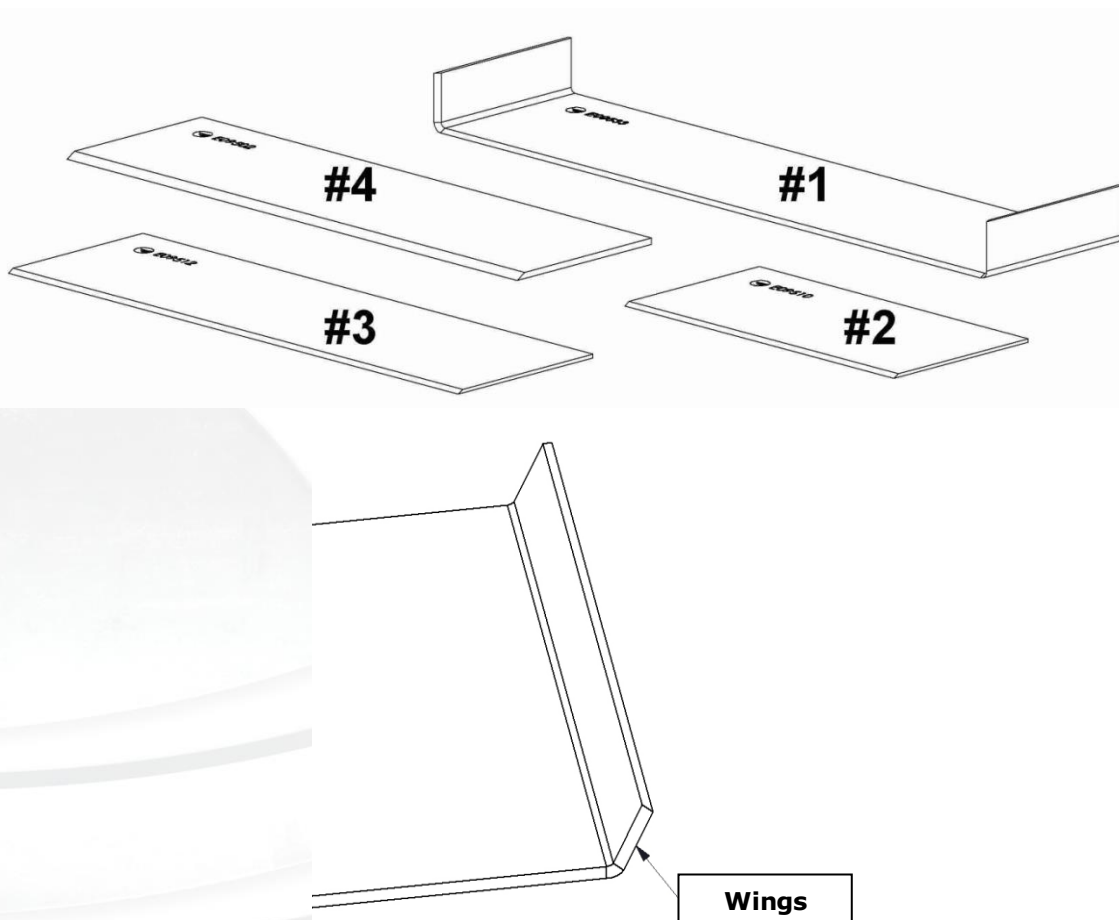

It's important to keep the "wings" sharp. They can be sharpened in the same way like the other blades.

Efficient and fast work can be reached by using correct blades and settings. During work the blade will become dull. When the blade is dull it is necessary to sharpen or replace it.

Having a second cutting head will be helpful, and it **will save you important time and money.**

When the machine is running on the second set of tools, the first set can be serviced.

Different parameters of coat or material will require the use of different blades. For example a small blade is perfect for the hard job. But when the material is soft you can use wide blade. The best solution is to start with a narrow blade and during work change it to a wider one if this is possible.

Working place should be kept clean. When some part of material is removed on the first run, it is always better to clean the floor before starting the second run. Debris and dirt can make the blade dull really quick.



Always wear protective, cut-resistant gloves before handling the blades!

Sharp blades can cause serious injury!

Blade changing

Dull blades greatly reduce cutting ability. Re-sharpen or replace as needed.

- Always wear protecting cut-resistant gloves when changing the blades.
- Use an extended wrench to keep hands safely away from the edge of the blade.
- Make sure the main plug is pulled out of the power source before changing the blades.

Place a block (1) under the front of the machine, or lay the machine all the way back on the steering handle.

Loosen the five hexagon head bolts and replace the blade. It is not necessary to remove the bolts. Be sure that the blade is far enough under the blade holder, to insure a secure hold.

Never leave the machine unsecured on jobsites.

Only change the blades if the machine is stable! When it is resting on a block (picture 1) or when the machine lays on a flat horizontal and levelled surface, as shown in picture 2.

Never change the blades when the machine is unstable, machine could fall back down, as shown in picture 3.

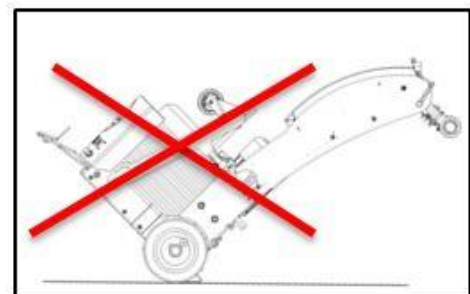
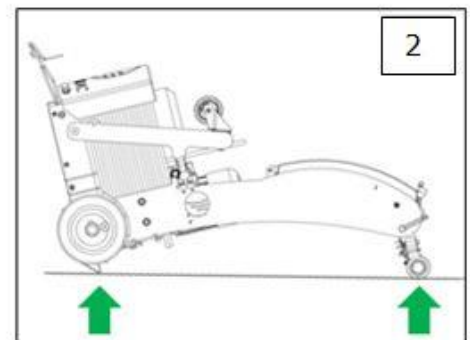
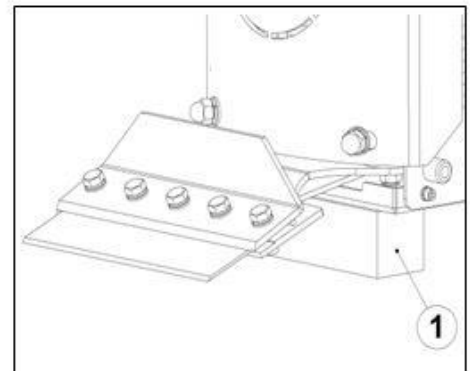



Blade sharpening

Always wear protecting, cut-resistant gloves and safety glasses. It is not necessary to remove the bolts. Sharpen the blade mounted to the machine. Using a hand grinder, block up the front of the machine so the blade is off the floor. Sharpen the blade with a 10 cm diameter disk with 120 or finer grit. **WARNING!** Be careful, make sure the disc does not catch the edge or corner of blade.

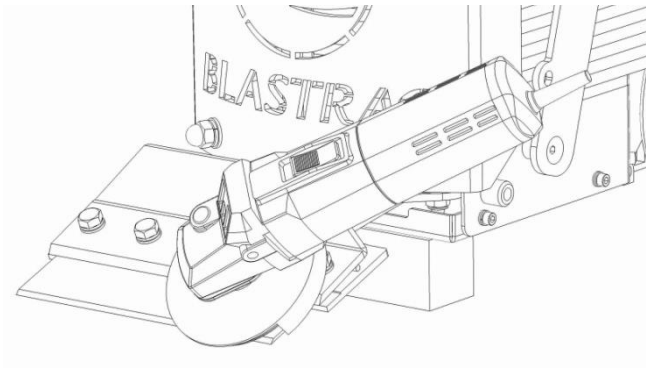

Blade bevel up

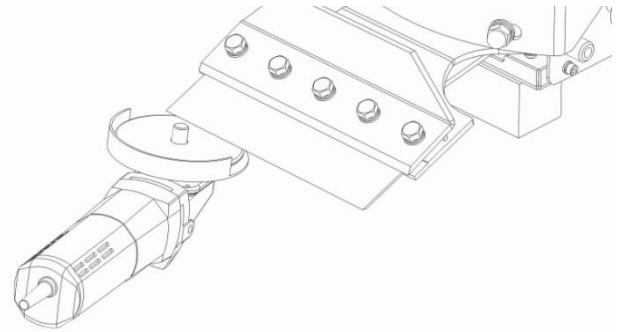

Blade bevel down

Furthermore there is the opportunity to remove the blade from the machine and to sharpen the blade at a vice, obeying the same way as shown in figures above.

5.5 Start up machine

- Before start-up the operating personnel must be familiar with the safety regulations given in this manual.
- Before switching on the machine make sure that no-one can be endangered when the machine starts up.
- Persons who are not operating the machine must not be permitted to stay in the surrounding area of at least 5 meter from the machine.

1. Selection switch must be on '0' position
2. Turn speed control to slowest position.
3. Plug in the main plug.
4. Turn the selection switch to '2' position.
5. Engage forward or reverse switch.
6. Increase speed control to desired speed.

The frequency drive has been factory set, do not change any setting of the frequency drive. Do not lock the levers for wheel drive into a permanent position. If the operator would lose control or be disabled, the machine continues to operate.

WARNING! If there is a power failure or the machine stops for any reason, always put the selection switch back to '0'!

NEVER leave the machine when the selection switch is in position '1' or '2'! When the power failure is rectified and the machine is still in position '2', the machine will start vibrating automatically!



Do not add weight on the machine!

Do not stand on the machine!

Do not block the airflow of the vibration motor!



5.6 Types of tear outs

Keep blades sharp! Keep your work area clean and clear of debris.

Always wear personal Protective equipment when working with the machine.

VCT - Tile

Never use a blade wider than the size of the tile being removed.

If goods being removed still do not come up clean or the machine jumps on top of goods, reduce blade size to a smaller blade until proper blade size is found or use a smaller portion of the blade.

Vinyl-, Rubber, PVC, Direct glued carpet

Goods will need to be scored down to 254 to 305 mm for proper removal.

Pre-scored carpet makes the machine easier to control and blades stay sharper longer. Blades up to 685 cm wide can be used. Normally 305 mm blades are used on direct glued carpet, secondary backed, unitary, double glued, vinyl foam, urethane foam. Latex foams come up easily with a 685 mm blade.

Self scoring blades can be used with some materials. A 254 mm blade is recommended for this product, but determine what size blade works best.

Ceramic (glued with double duty or mud sets):

Before removing ceramic tile, tiles will have to be pre-broken with a mallet or large hammer. On small random block styles of tile, pre-breaking may not be necessary.

Open an area large enough for machine or blade to fit in, or start from a doorway. Keep work area clean to keep good wheel contact with floor. Use slow speed and small blades.

Blades can be offset in cutting head for easier access to toe kicks or removal along the wall.

Wood and wood like floors

Pound down or remove any nails or metal obstruction to avoid blade damage.

Glued hard wood flooring

A 254 mm blade is recommended for regular adhesive, a 152 mm blade for epoxy.

For proper removal of hardwood flooring (plank solid, plank laminated, parkay, parquetry laminated) flooring must be scored to blade width.

This is done by using a circular saw set at a depth of 99% of the thickness of the board, just missing the subfloor surface when on concrete

A chalk line for scoring lines can be used across the floor the width of the blade

True parkay flooring scoring is not necessary. It will come up in small pieces.

When working over plywood sub-flooring, try to run machine in the same direction as the grain in the wood. Blade in most cases bevel down. On solid wood floors like plank, run in the same direction as the plank, not cross grain or cross plank. Removing the front counterweights will help on all soft surfaces.

Concrete

When working on concrete slab, normal blade position is bevel up for best performance, especially when cleaning adhesive. On occasion, bevel down gives better blade life.

Gibcrete and soft poured flooring

Usually requires blade bevel down to create a better wearing surface, although bevel up may work if some weights are removed.

Beware of expansion joints and floor mounted receptacles or other obstacles in the floor.



5.7 Ditching

Cross room ditching

When removing hard to remove ceramic, Vct or vat, cross-room ditching will help to make the removal easier. Using a blade 50 to 155mm in width, make ditches 300 to 600mm apart in the same direction as the machine will be removing the goods.

This "relieves" the pressure holding the tiles together. If ditching helps and the goods are coming up easy, try using a wider blade to ditch with.

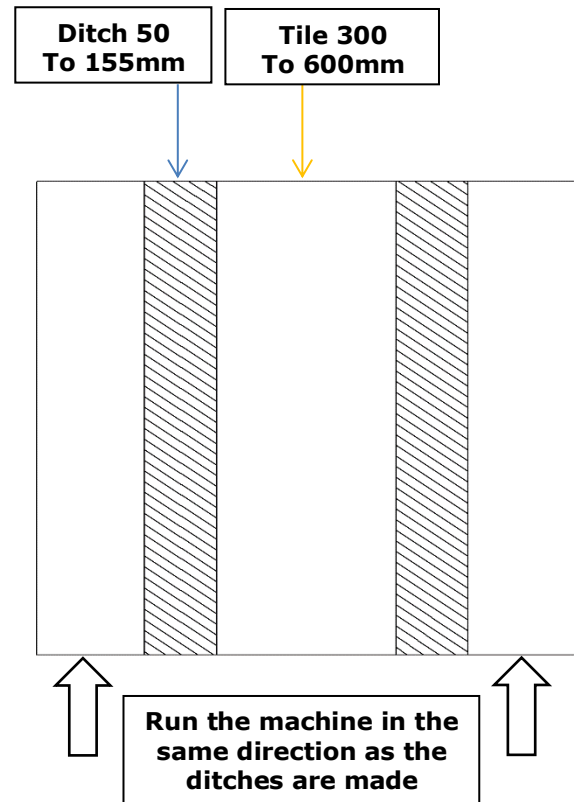

Checker board ditching

To make carpet removal and debris cleanup easier, checker board ditching is very helpful. Using as wide of a self-scoring blade as possible, make ditches apart crossways from the way the machine will be removing the goods. Running the machine crossways from the ditches will make smaller pieces of debris to be hauled away. Instead of large gummy rolls of carpet, there are small squares that can be rolled, palletized, put on a dolly or folded with the sticky side in. This makes removing the debris faster, easier and reduces the amount of debris.

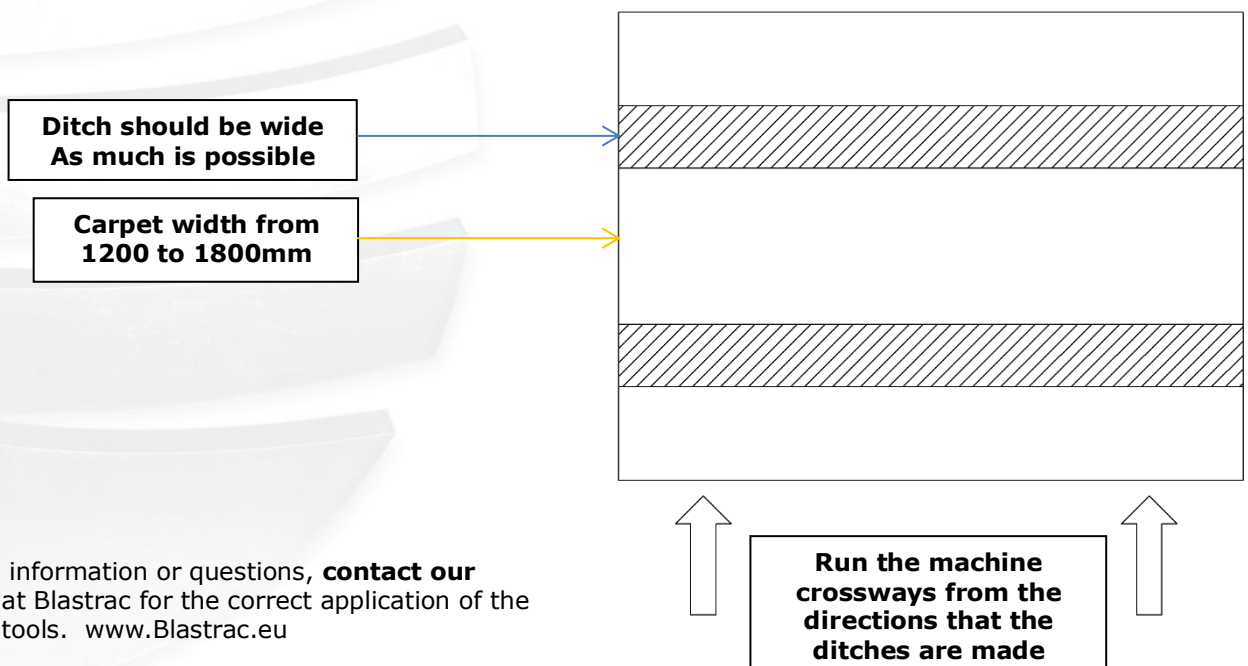

For more information or questions, **contact our experts** at Blastrac for the correct application of the different tools. www.Blastrac.eu



5.8 Removing weights

To remove weights, unscrew two M12 nuts at the front and remove the cover. Now it is possible to remove weights by hand. When mounting the cover check if the cover is good positioned and if the two nuts are good tightened.

Warning! The weights are heavy, ask a co-worker for assistance.

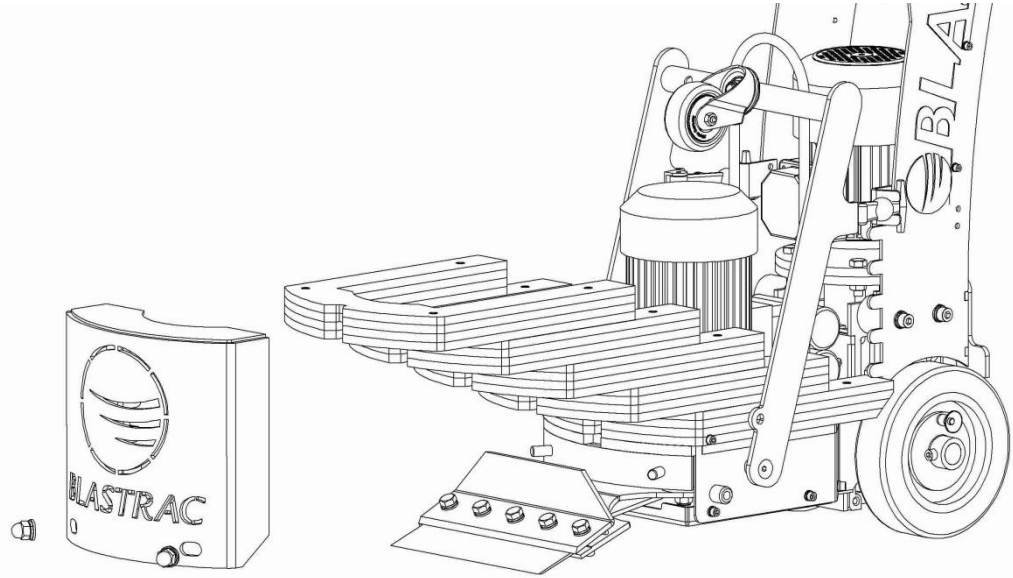



5.9 Angle adjustment plates 4° and 8°

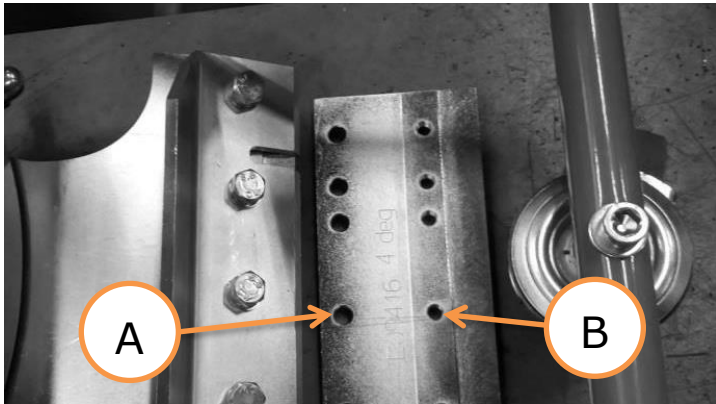

Mind the placement of the Angle Adjustment.
 The holes Ø10.5 without thread should be at the "machine-side". (A)
 The threaded holes M10 should be at the "frontwheel-side". (B)
 A: Hole Ø10.5
 B: Screw thread M10

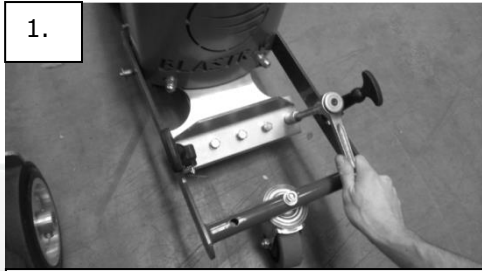
1. 

Remove the 5x M10 bolts of the Blade Cover.

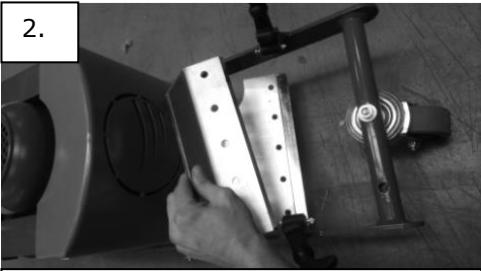
2. 

Remove the Blade Cover.

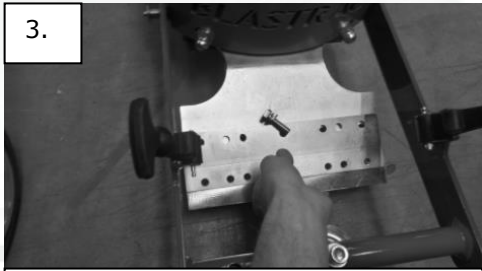
3. 

Place the Angle Adjustment.

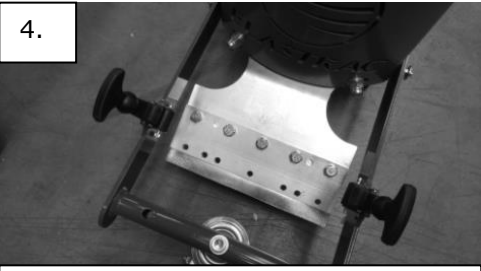
4. 

Fasten the Angle Adjustment with 5x M10x25 bolt 8.8 + Springlock washer + Washer

5. 

Place the Blade Cover over the Angle Adjustment.

6. 

Fasten the Blade cover.



6. Maintenance

Pay attention to Chapter 3 "**Safety**" during maintenance and repair works.

Failures due to inadequate or incorrect maintenance may generate very **high repair costs** and long standstill periods of the machine. **Regular** maintenance therefore is imperative. Also with proper maintenance the machine will produce less hand- arm transmitted vibrations.

Operational safety and service life of the stripper depends, among other things, on proper maintenance.

The following table shows recommendations about time, inspection and maintenance for the normal use of the stripper.

Operating hours/ time period	Inspection points, maintenance instructions
12 h after repairing	Check all accessible screw connections and other fasteners for tight seat.
Daily and prior to starting work	Check that all safety devices are working adequate. Check the function of the residual current operated device. Check the blades for wear and sharpness. Check the electric connections for sediments of dirt or foreign bodies. Check the electric motors for dirt and other contaminants.
Weekly	Check the conditions and tightness of the connections of the frequency drive. Remove any dust from the frequency drive. Ensure proper fan operation of: the frequency drive, the vibration motor and drive motor. Check for physical damage to the covers of the: the frequency drive, the vibration motor and drive motor.
Annually	Full overhaul and cleaning of the complete machine, including replacement of the shock absorbing parts.

The time indications are based on uninterrupted operation. When the indicated number of working hours is not achieved during the corresponding period, the period can be extended. However a full overhaul must be carried out at least once a year.

Due to different working conditions it can't be foreseen how frequently inspections for wear check's, inspection, maintenance and repair works ought to be carried out. Prepare a suitable inspection schedule considering your own working conditions and experience.

Our specialists will be happy to assist you with more advice.

Prior to any repair works on the machine and its drives, secure the machine against unintentional switching on. Make sure the main plug is pulled out of the power source.

Follow additional operating and maintenance instructions of Original Equipment Manufacturers if included during your service and maintenance work.

Further is advised:

Store the cleaned and dry machine in a dry and humid free room. Protect the electrical motors from moisture, heat, dust and shocks.

All repair work must to be done by qualified Blastrac personnel, this to guarantee a safe and reliable machine.



Any guarantee on the machine expires when:

- Non original Blastrac parts have been used
- Repair work is not done by qualified Blastrac personnel
- Changes, add one's or conversions are undertaken without written permission from Blastrac BV.

6.1 Wheel scraper plates

The wheel scraper plates keep the wheels clean from dirt/debris. To adjust or clean the scraper plates unplug electrical supply cable and loosen the bolts. Slide up to face wheel until it touches but does not dig into the wheel surface. Over tightening scraper plates could cause damage to wheel.

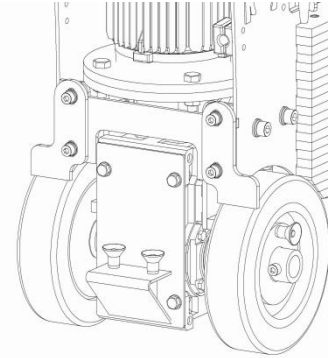

6.2 Replacing shock absorbers

To replace the shock absorbers first remove the weights as described in chapter 5.8. Unscrew the 6 bolts of the bottom cover, then remove bottom cover. Unscrew the five M10 nuts of the cutting head and remove cutting head. Remove the five big washers on shock absorbers. Unscrew the bolts of the shock absorbers at top. Replace shock absorbers with the new ones and apply Loctite on bolts to secure them. Put the five big washers on the shock absorbers. Carefully place the cutting head on the shaft. Do not use a hammer to prevent damage to the bearings. Tighten the five nuts of the cutting head, mount the bottom cover and mount the weights with the cover.

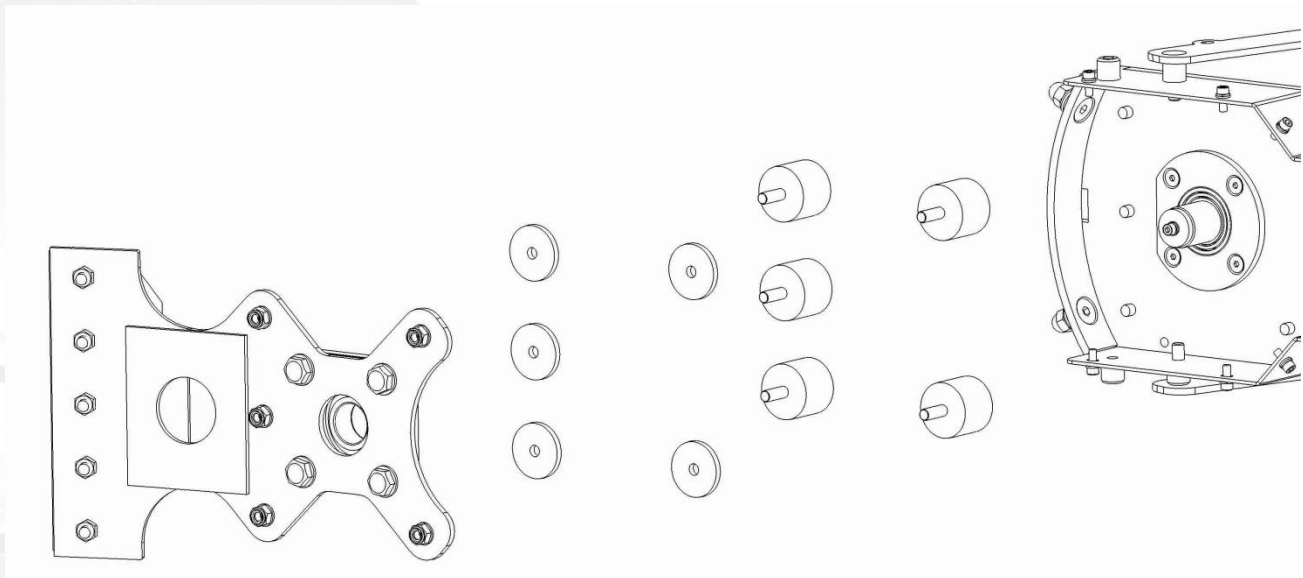



6.3 Frequency inverter

Caution! Work on the frequency inverter(9) by unqualified personnel or failure to comply with warnings can result in severe personal injury or serious damage to material.

Only qualified Blastrac personnel trained in the setup, installation, commissioning, operation and repair of the product should carry out work on the frequency inverter(9).

! Risk of electric shock. The DC capacitors remain charged for 15 minutes after power has been removed. It is not permissible to open the equipment until 15 minutes after the power has been removed.

! Caution. Do not perform a voltage test on parts inside the inverter. High voltage can destroy the semiconductor components.

If there is a problem with the frequency inverter, observe the error display, write down the error code and **contact Blastrac.**

Always mention the serial number and year of manufacture of the BS-110 machine, they can be found on the typeplate of the machine.

Do not attempt to open the frequency inverter.

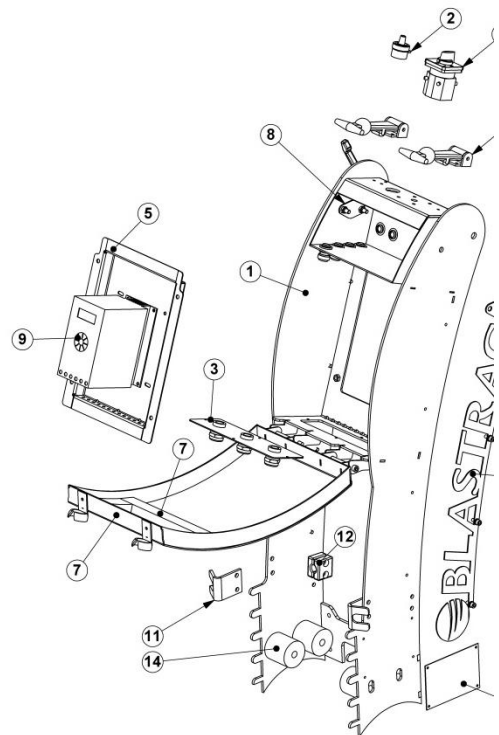
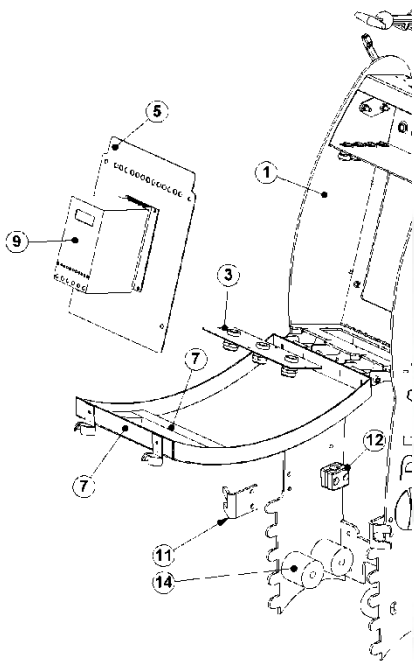

TECO		
Item	Part number	Description
5	E09352	Plate for frequency inverter 220V IP20
5	E09365	Plate for frequency inverter 110V IP20
9	E09349	Frequency inverter 220V IP20 3x230 out
9	E09351	Frequency inverter 110V IP20 3x230 out

Schneider		
Item	Part number	Description
5	E12823	Mount plate frequency inverter UNI
9	E09349-1	Frequency inverter 230V IP20 3x230 out From serial number 26145B & up.
9	E09351-1	Frequency inverter 110V IP20 3x230 out



The following failure codes indicate problems (TECO)



Display	Content	Cause	Corrective action
-LV- -LU-	Voltage too low	Power voltage too low Extension cord too long or damaged. Damaged wire in power supply cable	Check if the power voltage is correct. Try to use the machine without extension cord. Check the power supply cable for damages.
-OH- / OH-C -OH- OH-C	The inverter is overheated	Ambient temperature is too high	Improve the ventilation conditions, let the machine cool off.
OV-C OU-C	Excessive Voltage during operation/ deceleration	Power voltage varies widely (fluctuates)	Check power supply
-PF- PF	Input phase Loss	Abnormal fluctuations in the main circuit voltage	1.Check the main circuit power supply wiring. 2.Check the power supply voltage
OL1 OL1	Motor overload	Loading too large	Work being performed is too heavy.
OL2 OL2	Inverter overload	Excessive Load	Work being performed is too heavy.
LV-C LU-C	Voltage too low during operation	1.Power voltage too low 2.Power voltage varies widely (fluctuates)	Improve power quality









For all other failure codes: write down the failure code and serial number of the BS-110. Stop the machine and contact Blastrac.



The following failure codes indicate problems (Schneider)

From serial number 26145B & up.



Display	Content	Cause	Corrective action
USF 	Undervoltage	<ul style="list-style-type: none"> • Line supply too low • Transient voltage dip 	Check if the power voltage is correct.
TJF  OHF 	The inverter IGBT is overheated. Drive overheated.	<ul style="list-style-type: none"> • Drive temperature too high. • IGBT internal temperature is too high according to ambient temperature and load. • Ambient temperature is too high. • Work being performed is too heavy. 	Improve the ventilation conditions. Check the cooling fan. Wait for the drive to cool before restarting. Reduce workload.
OSF 	Main overvoltage	<ul style="list-style-type: none"> • Line voltage too high: <ul style="list-style-type: none"> - At drive power-on only, the supply is 10% over the maximum acceptable voltage level. - Power with no run order, 20% over the maximum line supply. • Disturbed line supply. 	Check power supply. Turn Off the machine. Check and adjust the line voltage. After line come back to nominal voltage (within tolerance) do power On.
SCF 1  SCF 3 	Motor short circuit	<ul style="list-style-type: none"> • Short-circuit or grounding at the drive output. • Ground fault during running status. • Commutation of motors during running status. • Significant current leakage to ground if several motors are connected in parallel. 	Check the main circuit power supply wiring. Check the cables connecting the drive to the motors, and the motor insulations.
OLF 	Motor overload	<ul style="list-style-type: none"> • Triggered by excessive motor current. 	Work being performed is too heavy. Reduce workload.
SCF 5 	Load short circuit	<ul style="list-style-type: none"> • Short-circuit at drive output. • Short circuit detection at the run order or DC injection order. 	Check the cables connecting the drive to the motors, and the motor's insulations.
OCF 	Overcurrent	<ul style="list-style-type: none"> • Inertia or load too high • Mechanical locking 	Work being performed is too heavy. Check the state of the mechanisms. Check the ground connections of drive, motor cables and motor insulations.

For all other failure codes: write down the failure code and serial number of the BS-110. Stop the machine and contact Blastrac.



6.4 Wheel bearings

The E09315-2 drive wheel does not have a needle bearing anymore, it has a "slide-bearing" inside (also called split bearing bush).

The steel backing provides mechanical strength and the bronze inter layer (impregnated with the PTFE lead Mixture) provides a strong mechanical bond for the lining. During normal operation, a thin film from the PTFE lining is transferred to the opposing surface and maintained there throughout the working life of the bearing.

It is very important **NOT** to use any grease or break cleaner spray on these type bearings!
Using any grease or spray can damage the PTFE lining and thus destroying the sliding abilities. The bearing should be placed on clean and dry surfaces.

The new slide bearings are water resistant.



Needle bearing
(Old situation)



Slide bearing
(New situation)

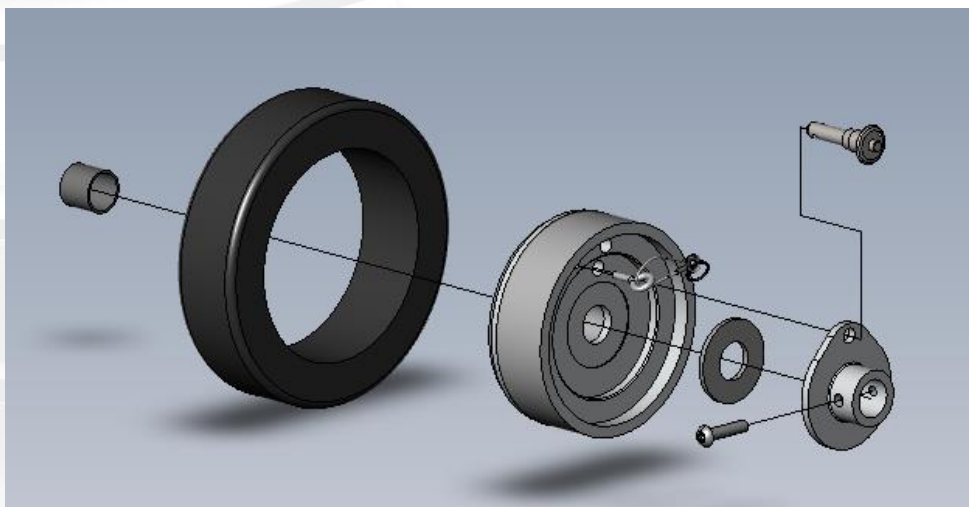

Important!
DO NOT use any grease or break cleaner spray on slide bearings!

7. Technical data

BS-110	
Drive motor power	0.75 kW
Vibration motor power	0.75 kW
Drive speed Min. / Max.	Min. 2,4 m/min up to 18,5 m/min
Application	Hardwood parquet / ceramics / linoleum / vinyl / carpet / adhesives / glue / tiles etc...
Length (L)	899 mm
Width (W)	522 mm
Height (H)	1062 mm
Minimum height steering handle (H1)	888 mm
Maximum height steering handle (H2)	1081 mm
Weight	170 kg
Environment	Temperature range from (14 to 104°F) or (-10 to 40°C) Relative humidity of max. 95%

The electrical diagrams of the electrical system are placed inside of the control panel.
Design and specifications are subject to change without notice by Blastrac B.V.

The BS-110 230V can be used in 50hz & 60hz.
The BS-110 110V can also be used in 50hz & 60hz.

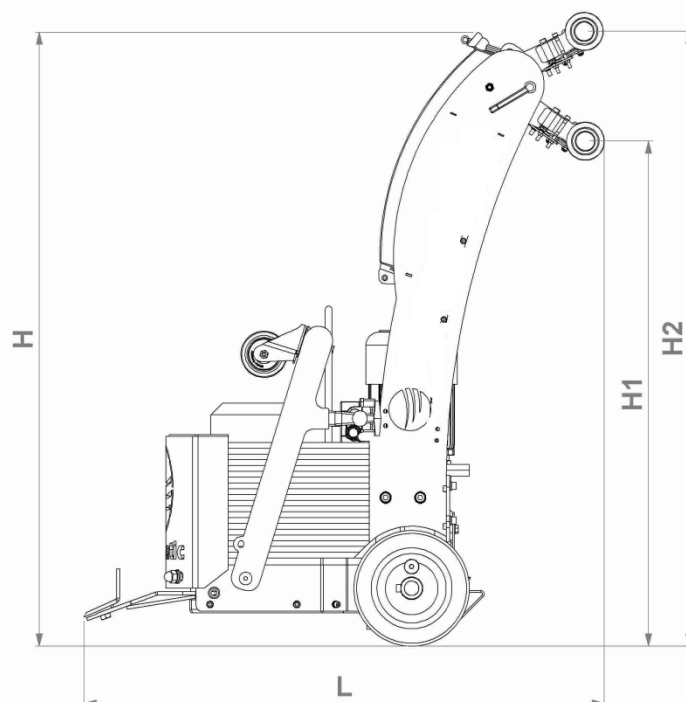
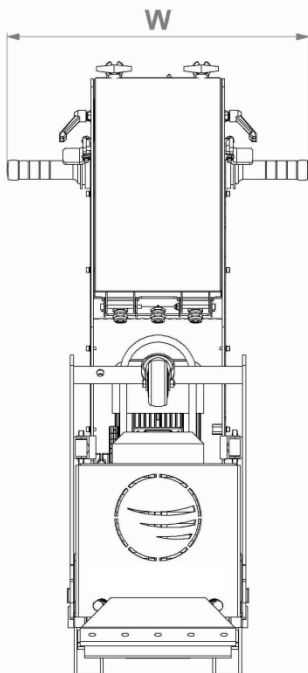



7.1 Sound and vibration data

Noise emission pressure level:

This document gives the results of the measurement of the emission sound pressure level on the Blastrac BS-110 MKIII floor stripper. The measurements have been executed in conformance with EN-ISO 11202:2010. There is no machine specific test code available.

Declared dual number emission value of the BS-110 in accordance with EN-ISO 4781.

The A-weighted emission sound pressure level L_{pAd} (at the operating position re. 20 μ Pa)	75 dB(A)
Uncertainty K_{pA} in dB.	2,5 dB

Although the sound pressure level at the operators position does not exceed 80 dB(A), ear protection is still strongly recommended when working with this machine.

Vibration level:

Declared hand- arm vibration emission in accordance to EN 12096.

Measured hand- arm vibration	4,6 m/s^2
Uncertainty K	1,2 m/s^2

Vibration test code EN-ISO 20643. Expanded uncertainty K (EN 12096 annex B).

Exposure to hand- arm vibration is 4,6 m/s^2 which allows continuous work for 9,3 hr. per day.

Because the value is above 2,5 m/s^2 , we recommend to use measures to decrease hand-arm vibrations.

Tips for decreasing the exposure to hand- arm vibrations:

- Protect the hands with vibration dampening gloves
E12000 – Anti-vibration gloves
- Switch off the vibrating motor when driving backwards
- Use only sharp blades
- Proper maintenance of the machine
- Scheduled replacement of the shock absorbing machine parts
- Keep the hands warm
- Prepare a work schedule and plan in rest periods

IMPORTANT NOTES:

The indicated values are measured on new machines. Sound and vibration levels will vary in different circumstances. Area influences like open outside or closed inside space, ambient temperature, the surface to be treated, etc. will give different values at all time and could increase the exposure level over the total working period.

The declared vibration and noise emission levels represents the main applications of the machine. However if the machine is used with different accessories or poor maintenance, the vibration and noise emissions may differ. The values may be used for a preliminary assessment of exposure.

For a precise estimate of the vibration and sound load, the times should also be considered during which the machine is switched off or even running, but not actually in use. This may significantly decrease the exposure level of the operator over the total working period.

Identify additional safety measures to protect the operator from the effects of vibration and noise such as: proper and regular maintenance of the machine and the accessories, keeping the hands warm, provision of proper hearing protection and organization of work patterns for example by using rotation schedules.

7.2 Extension cables

Cable length	Cross section			
	≤ 16 A	≤ 32 A	≤ 63 A	≤ 125 A
Calculated at a pre-fuse GG:	16amp*	32amp*	63amp*	125amp*
> 20m	1.5 mm ²	2.5 mm ²	10 mm ²	25 mm ²
20m > 50m	2.5 mm ²	4 mm ²	10 mm ²	25 mm ²
50m > 75m	4 mm ²	6 mm ²	16 mm ²	35 mm ²

*The cross-sections need to be re-calculated when using any other type or size pre-fuse than mentioned.

Old equipment contains valuable materials which are valuable for re-processing. **The machine parts must not be thrown away in the normal household waste**, but should be disposed of at a suitable proper collection system, e. g. via your communal disposal location. This way the materials can be re-used in an environmentally responsible manner.

Despite the fact that this guide is made with care, Blastrac takes no liability for errors in the manual and the possible consequences. We are naturally very interested in your findings and additions. No part of this publication may be reproduced and / or published in print, photocopy, or other form without prior permission by Blastrac.



BLASTRAC EUROPE

WE'RE READY TO ASSIST YOU!

BLASTRAC THE NETHERLANDS

EUROPEAN HEAD OFFICE

Utrechthaven 12
 NL - 3433 PN Nieuwegein
 Tel.: +31 (0)30 601 88 66
 Fax: +31 (0)30 601 83 33
 Email: info@blastrac.nl
WWW.BLASTRAC.EU

BLASTRAC POLAND

SALES & SERVICE CENTRE

Golina, ul. Dworcowa 47E
 63-200 Jarocin
 Tel.: +48 (0)62 740-41-50
 Fax: +48(0)62 740-41-51
 Email: info@blastrac.pl
WWW.BLASTRAC.PL

BLASTRAC FRANCE

SALES & SERVICE CENTRE

ZI - 29, Av. des Temps Modernes
 F - 86360 Chasseneuil du Poitou
 Tel.: +33 (0)5 49 00 49 20
 Fax: +33 (0)5 49 00 49 21
 Email: info@blastrac.fr
WWW.BLASTRAC.FR

BLASTRAC ITALY

SALES & SERVICE CENTRE

S.S. 10 Padana Inferiore, 41
 IT - 29012 Caorso (PC)
 Tel.: +39 0523 814241
 Fax: +39 0523 814245
 Email: info@blastrac.it
WWW.BLASTRAC.IT

BLASTRAC GERMANY

SALES & SERVICE CENTRE

Richard-Byrd-Str. 15
 50829 Köln
 Tel.: +49 (0) 221 709032-0
 Fax: +49 (0) 221 709032-22
 Email: info@blastrac.de
WWW.BLASTRAC.DE

BLASTRAC UKRAINE

SALES & SERVICE CENTRE

Nezalezhnosti 14, of. 21
 07400 Brovary
 Tel.: +38 (0)44 222 51 28
 Fax: +38 (0)44 277 98 29
 Email: info@blastrac.com.ua
WWW.BLASTRAC.COM.UA

BLASTRAC SPAIN

SALES & SERVICE CENTRE

Calle del Estío, 9
 E - 28500
 Arganda del Rey, Madrid
 Tel.: +34 91 660 10 65
 Fax: +34 91 672 72 11
 Email: info@blastrac.es
WWW.BLASTRAC.ES

BLASTRAC UNITED KINGDOM

SALES & SERVICE CENTRE

Unit 2a, Outgang Lane, Dinnington
 Sheffield, South Yorkshire
 GB - S25 3QY
 Tel.: +44 (0) 1909 / 569 118
 Fax: + 44 (0) 1909 / 567 570
 Email: info@blastrac.co.uk
WWW.BLASTRAC.CO.UK

BLASTRAC MIDDLE EAST

SALES & SERVICE CENTRE

P.O. box 29424
 Dubai / United Arab Emirates
 Tel.: +971 4 3245760
 Fax: +971 4 3245761
 Email: info@blastracdx.ae
WWW.BLASTRAC.AE

BLASTRAC NORDIC

SALES & SERVICE CENTRE

Lekstorps Industriväg 13D,
 443 41, Gråbo
 Sweden
 Tel.: +46 (0) 31 30 333 55
 Email: info@blastrac.se
WWW.BLASTRAC.SE

BLASTRAC INDIA

SALES & SERVICE CENTRE

G.B. Warehousing, GAT NO- 523,
 Pune- Nagar Road, Wagholi
 Pune- 412 207
 Tel.: +91 99213 98109
 Email: info.blastrac.in
WWW.BLASTRAC.IN