



Original instructions in English

# OPERATING INSTRUCTIONS BMS-150

VERSION 1.1





**Inspection comments**

Inspection before initial operation on:	_____
By:	_____
Date of initial operation:	_____
Serial number & Year of manufacture:	_____

**Recurring inspections / maintenance log**

Date / Hour counter	Findings	Repairs / Cleaning	Test on	By*

\*Competent person



## Table of contents

<b>Inspection comments</b>	<b>2</b>
<b>1 Introduction</b>	<b>4</b>
<b>2 Machine description</b>	<b>4</b>
<b>3 General Safety Rules</b>	<b>5</b>
3.1 Work area safety	5
3.2 Electrical safety	5
3.3 Personal safety	5
3.4 Machine safety	6
3.5 Dust collector safety	6
3.6 Maintenance safety	6
3.7 Transport safety	7
3.8 Signs on the machine	9
<b>4 Initial operation</b>	<b>10</b>
4.1 Checkpoints:	10
Electrical safety	
Machine safety	
4.2 Seat adjustment and proper seatbelt use	10
4.3 Adjust foot frame	11
4.4 Transport bracket	12
<b>5 Operation</b>	<b>13</b>
5.1 Electric controls	13
5.2 Controlling the machine	14
5.3 Driving the machine	14
5.4 Electric cable	15
5.5 Connect the electric cable	15
5.6 Folding the BMS-150	16
5.7 Start up the machine	20
<b>6 Blades</b>	<b>21</b>
6.1 Blade choice	21
6.2 Working method	22
6.3 Blade changing	23
6.4 Cutting head & Blades	24
6.5 Blade sharpening	25
6.6 Types of tear outs	27
<b>7 Maintenance</b>	<b>28</b>
7.1 Trouble shooting	28
<b>8 Technical data</b>	<b>33</b>
8.1 Dimensions of the machine	34
8.2 Sound and vibration data	36
8.3 Options	37
<b>Contact</b>	



## 1. Introduction

Before use, operators must be provided with information, instruction and training for the use of the machine and the substances for which it is to be used, including the safe method of removal and disposal of the material collected. All persons who are working with or maintaining this machine must read the manual carefully and understand it fully. In case you sell the unit, hand it on to the next owner. Keep this manual always with the machine, to enable it to be referred to at any time. Any other work not covered by this operating manual must not be carried out.

This machine is designed for industrial use by professionals. **Only authorized and trained personnel may operate this machine.** This machine is not intended for use by persons (including children) with reduced physical, sensory or mental capabilities, or lack of experience and knowledge. **Blastrac BV** offers a course on the use of the machine in order to make the operating and maintenance personnel familiar with all elements of the machine. Always use common sense when working with machines.

## 2. Machine description

The Blastrac BMS-150 stripper is ideally suited for small and medium sized applications. The machine has a strong electric drive system which is very easy to operate. The machine has forward, backward and speed control functions.

### Main assets of BMS-150:

- Electrical driven machine with two electrical motors.
- Forward and backward driving function.
- User and environmentally friendly; very low noise level, easy to operate and low vibrations.
- Very high output.
- Small and compact equipment, very easy for transportation.
- Transport bracket for manual moving the BMS-150
- Heavy duty equipment, which is almost maintenance free.
- A 25 mtr. automatic winding up power cable with an rotating cable arm.
- Quick release tool, to change or replace the blade very quickly.
- The cable system can be folded down, to have a lower height.
- Additional extra weight up to 200 kg. (weight kit and wheel weights).

1	Automatic electrical cable (25mtr) on a rotating cable arm
2	Operator seat, with pressure switch
3	Joysticks (2x) for moving BMS-150
4	Suction unit
5	Cutting head
6	Lights (3x)
7	Additional weights <i>optional</i>
8	Transport bracket, for manual moving BMS-150
9	Lifting points for a forklift (front and side)
10	Lifting points for a crane (3x)
11	Tool box

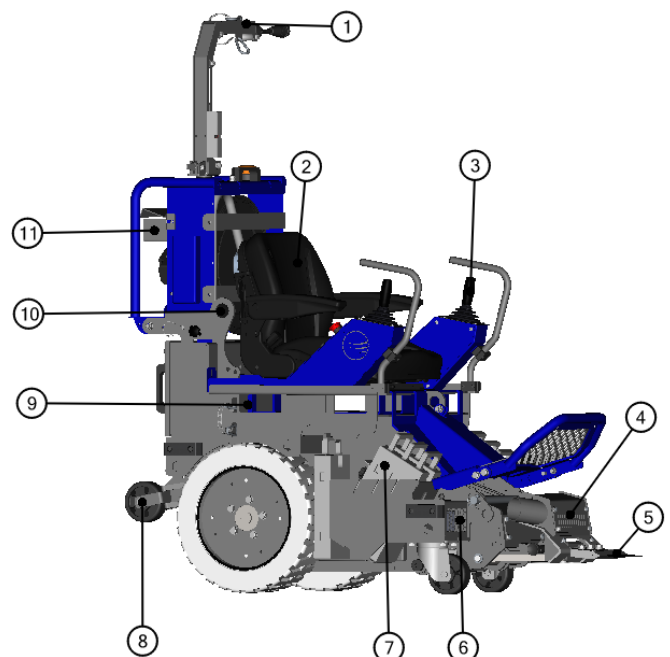





### 3. General Safety Rules

#### Warning!

**Read all safety warnings and all instructions.** Failure to follow the warnings and instructions may result in electric shock, fire, explosions and / or serious injuries.



Only authorized and trained personnel may operate this machine. This machine is not intended for use by persons (including children) with reduced physical, sensory or mental capabilities, or lack of experience and knowledge. Always use common sense when working with machines.

It is the responsibility of the user to analyse the surface to be treated. The surface may not contain any substances which could pose a fire-, explosion- or health risk when treated. The user should make a risk assessment on the basis of the information obtained about the surface to be treated and take proper precautions for the work to be performed.

In case of any inappropriate usage, improper operation or repair, the producer shall be exempt from liability.

#### 3.1 Work area safety

- a) Do not use the machine in rain, damp or wet locations.
- b) **Avoid dangerous environments:** do not work in the presence of explosive atmospheres, in the presence of flammable liquids, gases or dust. Remove materials or debris that may be ignited by sparks.
- c) Make sure there is enough ambient light on the work area. Cluttered or dark areas invite accidents.
- d) Keep children and bystanders away while operating the machine. They are likely not to foresee the potential dangers of the machine. Distractions could cause you to lose control of the machine.
- e) Secure the work area around the machine in public areas providing an adequate safety distance from the machine. Use a red and white safety chain and danger sign to enclose the work area if necessary.
- f) Persons who are not operating the machine must not be permitted to stay in the surrounding area of at least 5 meter from the machine.
- g) Never use the machine when the surface is not clear and if there is a risk of stumbling or tripping.
- h) Make sure that there is nothing standing or situated on the surface to be treated.
- i) Remove reinforcing steel or other objects protruding from the surface in order to prevent damage to the machine.
- j) Keep your work area clean and clear of debris.
- k) After you have removed a portion of material, remove it out of the way. This will give the machine maximum performance and will help to keep the work area safe.
- l) **Warning! Make sure that the surface to be treated does not contain dangerous materials such as:**
  - combustible or explosive dusts or substances.
  - carcinogenic or pathogenic substances.

**In these cases, additional safety measures should be used. Always mind the local safety requirements.** Contact your dealer for additional options.

#### 3.2 Electrical safety

- a) Any damage to the electric cables and/or electrical components is not permitted.
- b) The voltage on the identification plate must comply with the power supply.
- c) Use an electrical power supply connection with earth connection and earth leakage circuit breaker.
- d) **Keep the machine original; The machine is always equipped with an earthed connection, do not change this** and always use earthed cables with an earthed plug.
- e) Inspect and test the electrical components regularly. The electrical components have to satisfy with the requirements set out in the harmonised norm EN60204-1.
- f) Always call a skilled electrician or your distributor when you have questions about the safety of the electrical components.
- g) Work on electrical equipment or operating materials may only be undertaken by a skilled electrician or by trained persons under the guidance and supervision of a skilled electrician as well as in accordance with the electrical engineering regulations.
- h) Do not abuse the power cord. Never use the cord for carrying, pulling or unplugging the machine. Keep cord away from heat, oil, sharp edges or moving parts. Damaged or entangled cords increase the risk of electric shock.
- i) Be careful with water on the treated surface. Electrical cables must not come into contact with water.
- j) During a long standstill of the machine, pull out the main plug.
- k) The main power switch on the machine must be switched off before connecting to the power supply.



### 3.3 Personal safety

- a) **Always wear Personal Protective Equipment while working with or around the machine!**  
-Dust mask class FFP2 or higher - Hearing protection - Safety glasses with lateral protection  
-Protecting, cut-resistant & vibration dampening gloves - Safety shoes.
- b) Always wear close-fitting protective clothing. Do not wear loose clothing or jewellery. Keep your hair, clothing and gloves away from moving parts.
- c) Stay alert, watch what you are doing and use common sense when operating the machine.
- d) Always seek professional medical attention immediately in case of injury.
- e) All persons surrounding the machine should wear Personal Protective Equipment.

### 3.4 Machine safety general

- a) Safety functions and operating functions must work correct. Check daily if these work.
- b) No loose bolts, nuts or other fasteners are permitted.
- c) Never operate machine without the guards and/or safety devices in place.
- d) Never change anything on the safety devices on the machine!
- e) The machine, and it's components must be free of fats/oils and have to be dry.
- f) Do not **open** or **remove protective guards** while driving gears are running.
- g) Do not pull out the power supply cable by the wire, but by the connector.
- h) All repair work has to be done by qualified Blastrac personnel, this guarantees a safe and reliable machine.
- i) Always use original Blastrac spare parts and cutting blades, this will ensure the best performance.
- j) Only original parts meet the factory specifications and quality. Otherwise Blastrac BV cannot guarantee the safety of the machine. The part numbers can be found in the Service Manual.
- k) If safety-critical changes occur to the machine or its working method, the machine must be shut down immediately! The cause of the fault must be established, and rectified.
- l) In the event of operational malfunctions the machine must be shut down immediately and secured!
- m) Do not stand on the machine. Do not add extra weight on the machine. Except the optional weights.

### 3.5 Dust collector safety

- a) Always use a Blastrac dust collector to ensure a dust-free operation of the machine and clean air at the workspace.
- b) When working on or around **carcinogenic or pathogenic substances**, the dust collector must be fitted with a HEPA filter.
- c) Read the operating instructions of the dust collector before using it.
- d) The dust container/bag of the dust collector must be emptied regularly. Comply with the local waste treatment regulations considering the removed material.
- e) The dust hose must be connected properly with a hose clamp.
- f) The dust hose must be undamaged and free of obstructions.

### 3.6 Maintenance safety

- a) **Pull out the main plug before starting inspections and repairing on the machine.**
- b) Wait for standstill of all drives before any inspections, adjustments and/or maintenance work is started.
- c) Block machine in stable position before doing any maintenance work.
- d) Failures due to inadequate or incorrect maintenance may generate very **high repair costs** and long standstill periods of the machine. **Regular** maintenance therefore is imperative.
- e) Operational safety and service life of the machine depends, among other things, on proper maintenance.
- f) Prevent premature wear by keeping the machine as dust free as possible. Clean the machine for this reason regularly with a dust collector and non-aggressive materials. Never use a high pressure water cleaner to clean the machine.
- g) It is advisable to stock all spare parts or wear parts that cannot be supplied quickly. As a rule, production standstill periods are more expensive than the cost for the corresponding spare part.
- h) The suitable precautions for maintenance include decontamination before disassembling the machine, adequate filtered ventilation of the exhaust air from the room in which it is disassembled, cleaning of the maintenance area and suitable personal protection equipment.

### 3.7 Transport safety

- a) Be aware of your surroundings and machine operating level. Do not side hill, do not run on steep incline, this could cause machine to tip over.
- b) The weight of the BMS-150 is 480 kg without the extra weights. Use preferably appropriate appliances as a lift, crane or a forklift truck. Use the existing lifting points to lift the machine. Or the special holes for lifting the machine with a forklift truck
- c) Never lift the machine with mounted tool! This sharp tool can be very dangerous!**
- d) Don't leave the machine unsecured on jobsites.
- e) Park the machine always on a flat horizontal and levelled surface.
- f) Store the cleaned and dry machine in a humid free room. Protect the electrical motor from moisture, heat dust and shocks.
- g) Never use the machine for lifting persons or items.
- h) Before every use check the lifting points and welds for: deformation, damages, cracks, corrosion and wear.
- i) When lifting the machine from the ground, always use the lowest lifting speed. The cables must first be tensioned at this speed; they must not be slack when the machine is lifted from the ground.
- j) During hoisting make sure to be at a safe distance from the machine with the most optimal view on the machine and working environment.
- k) Never stand directly below the machine.
- l) When transporting the machine do so in such a manner that damage due to the effects of the use of force or incorrect loading and unloading is avoided.
- m) The lifting point can also be used to fasten the machine on a pallet or during transport.
- n) Never load or unload the machine on a ramp. Failure to do so could cause machine to run away, damage to the machine, damage to property or cause serious injury.

**Never lift the machine with mounted tool! This sharp tool can be very dangerous!**

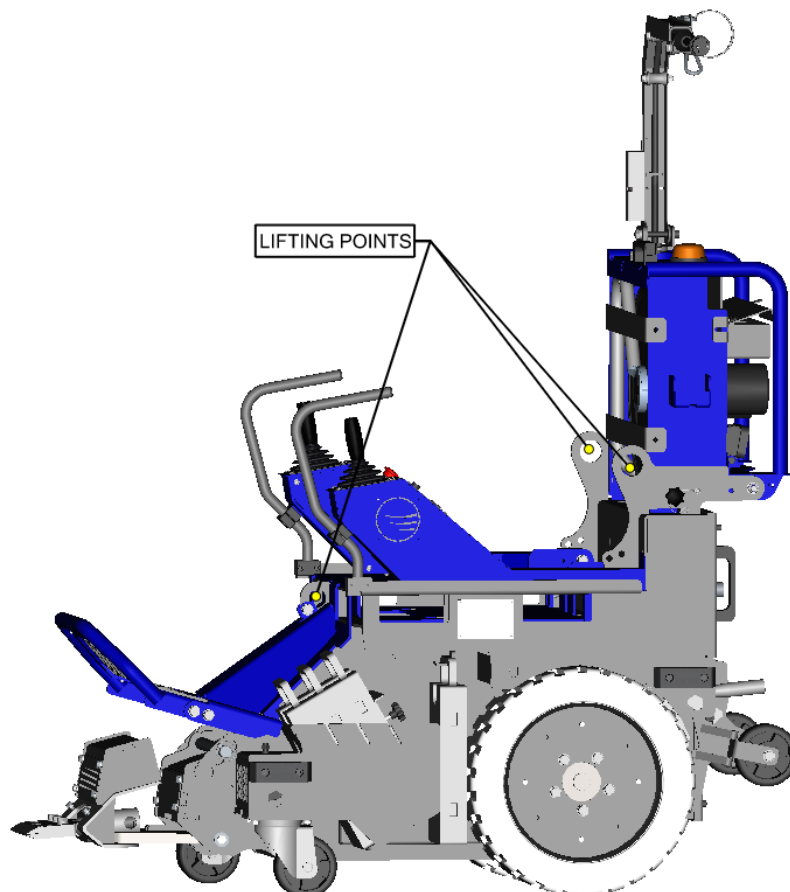

\* Operator seat is made hidden, to visualise the lifting points better.



Lifting points for the use of a forklift truck.

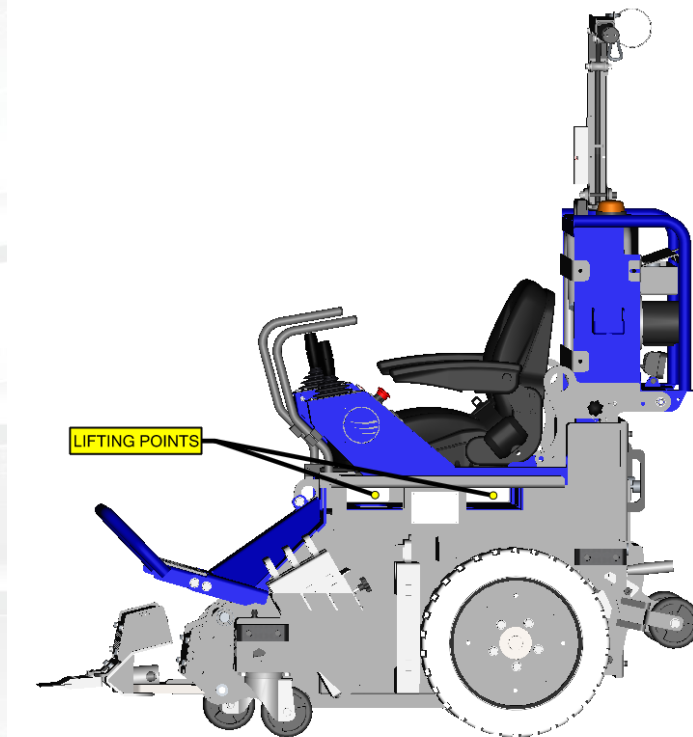
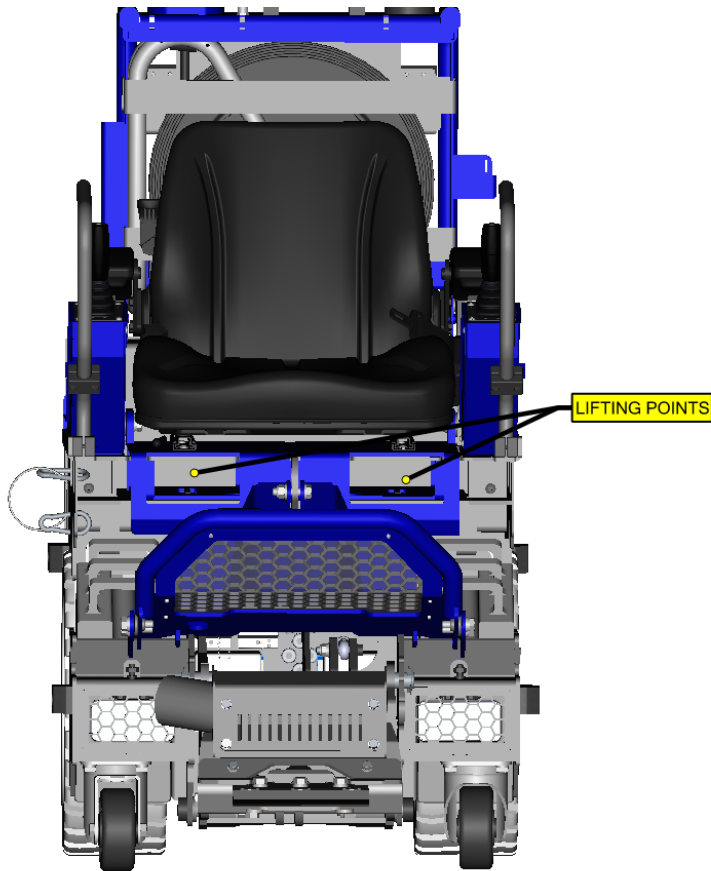





### 3.8 Signs on the machine

The following stickers are placed on the machine. Meanings of these symbols are:



! Danger Hazardous voltage in motor even when solid state controller is OFF. Disconnect main power before servicing motor, controller or associated wiring.



Lifting point.



Wear a dust mask class FFP2 or higher.



Hearing protection is obliged.



Safety glasses with lateral protection are obliged.



CE-mark on this machine.



Wear protecting gloves.



Safety shoes obliged.



Consult the manual before operating the machine.

Type plate:

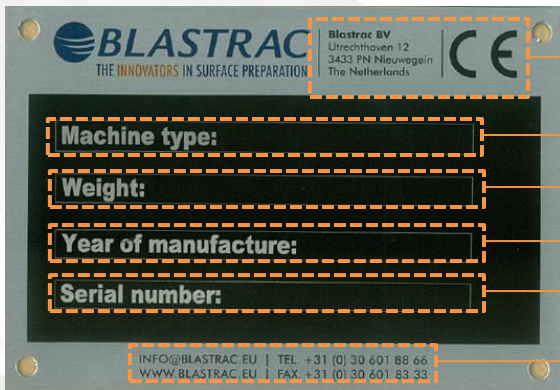

- Name, address and CE mark.
- The machine type.
- The net weight of the machine in kilogram.
- The year of manufacture.
- The serial number of the machine.
- Email address, Website, Telephone & fax number.

EU Declaration of Conformity:







## 4. Initial operation

Before using the machine it is of great importance to inspect the machine every day. It is not permitted to use the machine if the machine safety is not according the checkpoints below.

### 4.1 Checkpoints

#### Electrical safety

- Any damage to electric cables is not permitted.
- Use an electrical power supply connection with earth connection.
- The selection switch of the machine should be put to '0' (OFF) before connecting to the power supply.

#### Machine safety

Check if:

- The safety functions and operating functions work correct.
- There are not any loose nuts or bolts.
- Joysticks must be in neutral position.

### 4.2 Seat adjustment and proper seatbelt use.

To fasten your seat belt, pull the webbing (1) out of the retractor and insert the metal tongue into the buckle (3). There will be an audible "click" when the tab locks into the buckle. Pull on the strap (4) to tighten the lap belt across your hips. The lap belt should be worn snugly and as low as possible over the hips, do not wear it over your belly.

To release the belt, press the buckle release button (2) and allow the belt to retract. If the belt does not retract smoothly, pull it out and check for kinks or twists. Then make sure it remains untwisted as it retracts.

Periodically check the seat belt to be sure it remains snug and in position. If there is a sudden stop or impact, the belt will lock into position. It will also lock (restrict) if you try to lean forward too quickly.

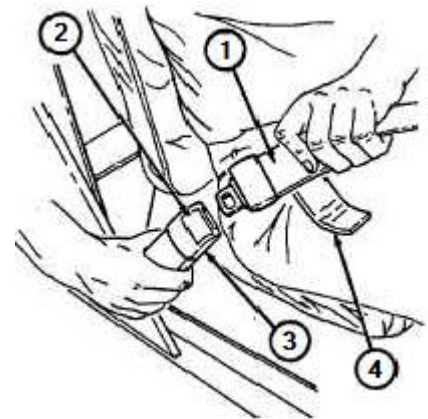

Seat belt usage is necessary to:

- Reduce the possibility of being thrown from the machine.
  - Reduce the possibility of injuries to the body during an accident or collision.
  - Hold the driver in a position which allows better control of the machine.
- 
- The operator should always wear the seat belt no matter how short the trip in order to minimize the risk of severe injury in the event of a crash or an emergency stop. In an accident, an un-belted operator becomes a projectile, and can cause serious injury to himself.
  - The belt must always be flat against your body and not twisted in any way. Nothing, such as an arm rest, a phone, or any external objects should be between you and the seat belt. Improper wearing of a seat belt will reduce the protection in an accident or collision.
  - Seat belts should be adjusted as tightly as possible, consistent with comfort to properly secure the wearer in the seat.
  - Do not use any accessories on the seat belt or modify in any way the seat belt system.
  - An accident or emergency stop, can damage your seat belt system, even if the accident is "minor". Please inspect the seat belt system after an accident.
  - Never use a damaged seat belt system. A damaged seat belt will not provide protection in an accident, resulting in serious injury.
  - Seat belt systems can be prone to abuse. They are not indestructible. They must be handled with care to avoid damage.
  - Keep the belts clean and dry. Belt retraction may become difficult if the belts and webbing are soiled. If they need cleaning, use a mild soap solution or lukewarm water. Never use bleach, dye, or abrasive cleaners. These chemicals will severely weaken the belts.



- Never wear twisted seat belts. Excessive forces will be transferred from the belt to the wearer, in a collision, resulting in serious personal injury.
- At least once each month, inspect the seat belt webbing for any cuts, tears, or other signs of wear (such as fraying along the edges). Also check if the seat belt is still operational.

### 4.3 Adjust foot frame

Folding the foot frame

Extend the Foot frame.

- Remove the 4 bolts, pointed by the green arrow.

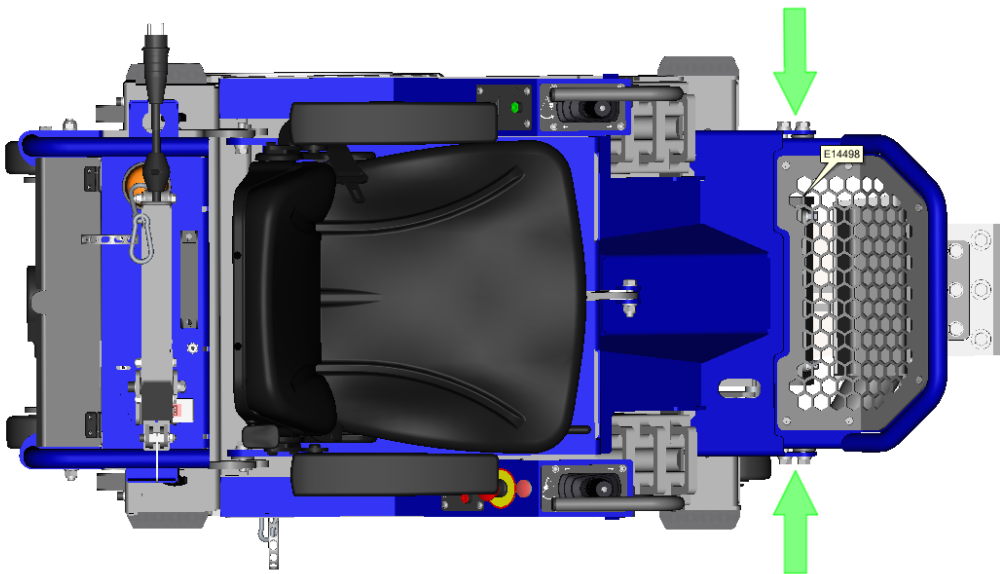

- Move the foot frame to the direction pointed by the green arrow, till the other holes can be noticed. And mount the foot frame again.





#### 4.4 Transport bracket

The BMS-150 can be moved around manually by using the transport bracket.

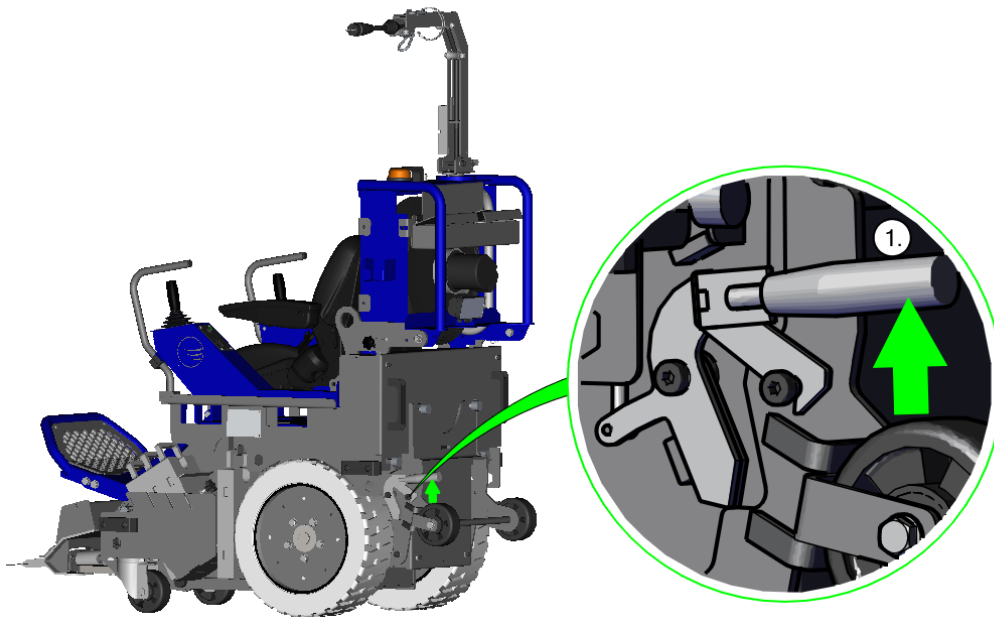

Using the transport bracket

- Disengage the transport bracket by pulling lever (1) up.
- The transport bracket will come down.

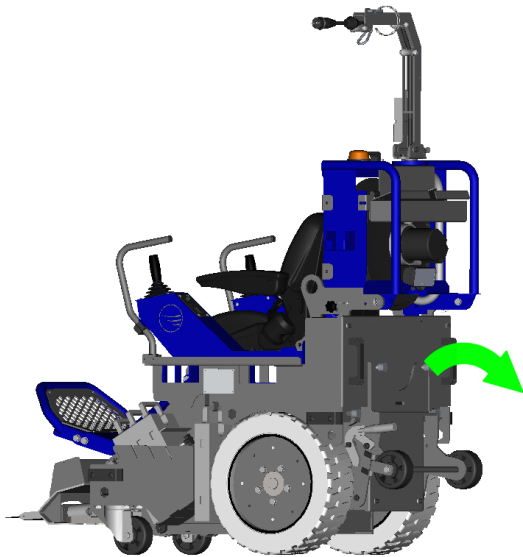

- Stand on the transport bracket, the BMS-150 will be lifted up by your weight. The lever (1) will lock the transport bracket. The lever will make a “clicking” sound, when it locks the transport bracket.

To lower the BMS-150 again for work.

- Stand on the transport bracket.
- Pull the lever (1) up.
- Transport bracket comes out of its locking position.
- Push the transport bracket in its beginning position.

Be careful! Make sure nobodies feet get under the wheels.

Wear appropriate safety shoes when you drive the machine to or from the work area.



## 5. Operation

### 5.1 Electric controls

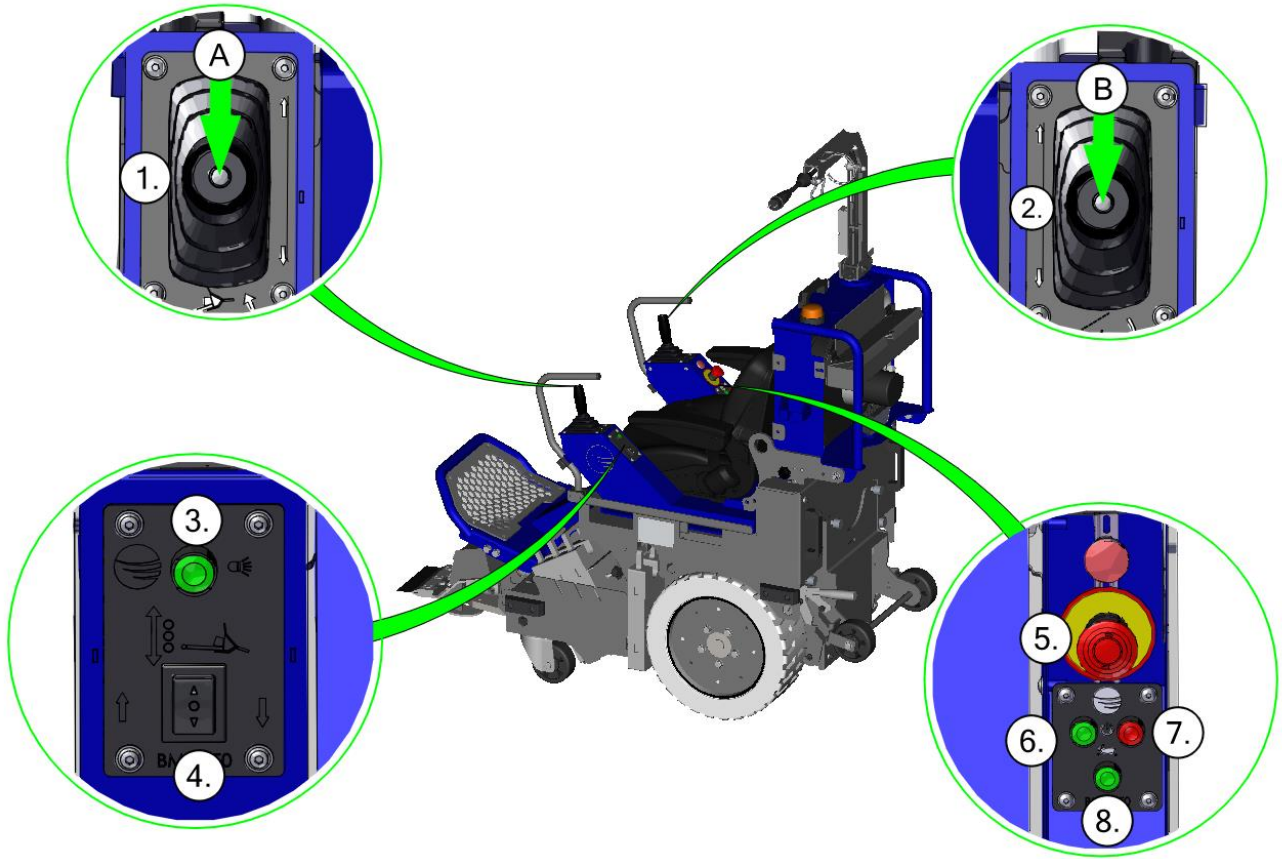

A	Move blade up
B	Move blade down
1	Joystick drive motor (Left)
2	Joystick drive motor (Right)
3	Lights on/ off
4	Tool position switch (Dual lift)
5	Emergency break button
6	"On" button
7	"Off" button
8	High speed (Hare)



## 5.2 Controlling the machine

- Take place on the seat and put your feet on the footplate. Fasten the seatbelt.
- Operating the machine when you are not sitting in the operator seat is not possible because of the safety switch inside the seat.
- Pull out the emergency break button (5).
- Use the button (6) to switch the BMS-150 on.
- Use the button (7) to switch the BMS-150 off.

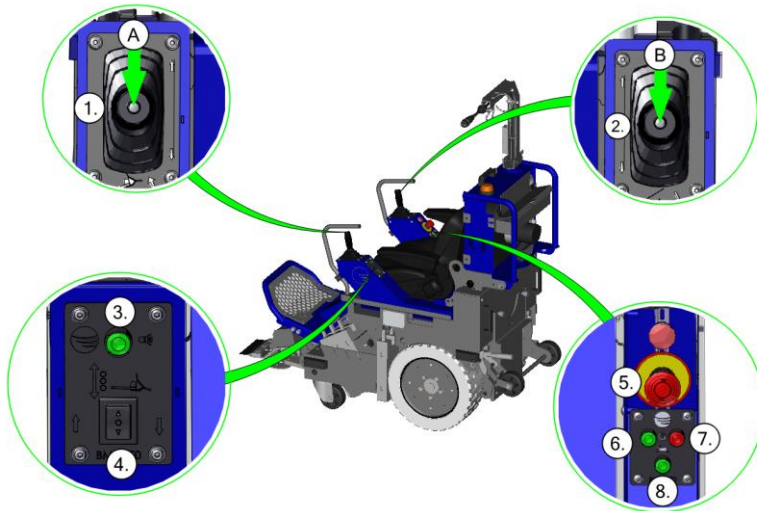

## 5.3 Driving the machine

Driving the machine is controlled by the two joysticks (1 and 2)

- Pushing both joysticks forwards, the machine drives forwards.
- Pulling both joysticks backwards, the machine drives backwards.

The driving speed depends on the position of the joysticks.

- Pushing the right joystick forwards the machine turns to the left.
- Pushing the left joystick forwards the machine turns to the right.

Pushing one joystick forwards and pulling another joystick backwards, the machine will turn around its axis. Correcting direction while moving is accomplished by slightly reducing pressure on one joystick or the other while moving.

Note: If there is 20 seconds of no activity, the BMS-150 will shut down. You have to restart the BMS-150 with the "On" button (6).



### 5.4 Electric cable

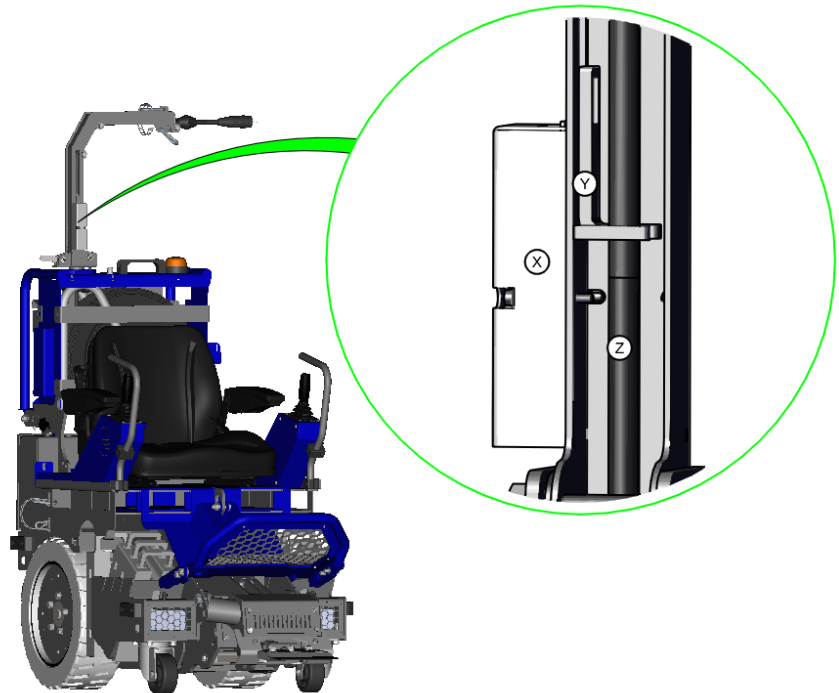

X	Electrical switch
Y	Lever, part of electrical switch
Z	Electrical cable

The BMS-150 has a 25 meter electric cable on an automatic reel. To prevent that the cable gets pulled out and get damaged, there are 2 safety devices that will indicate you reached the end of the electric cable.

1. Visual indicator; Approx. 1 -2 meters before the end of the cable, red markers will indicate you almost reach the end of the electric cable.
2. Electrical switch; If you ignore the markers and go further, the electrical switch will be triggered. When the switch is triggered you have to prepare the switch and start up the BMS-150 again.

So it is better to avoid triggering the electrical switch. And keep track of the visual indicator.

Do not extend the cable!!!

### 5.5 Connect the electric cable

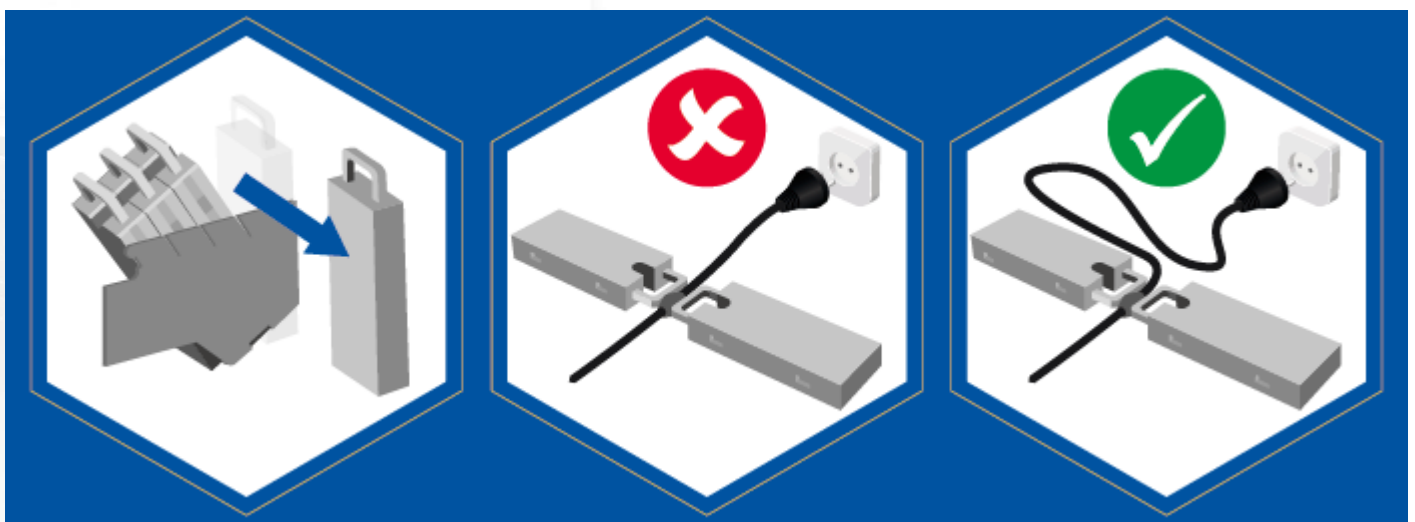



## 5.6 Folding the BMS-150

### STEP 1. Folding the rotating cable arm.

- Push the locking lever up.

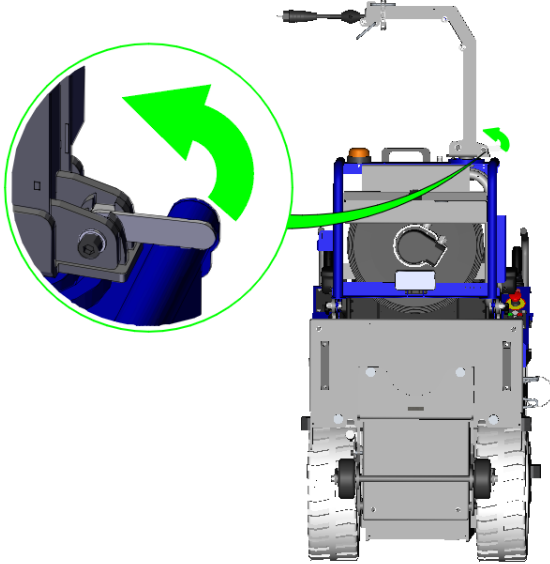

- Now you can fold the rotating cable arm.

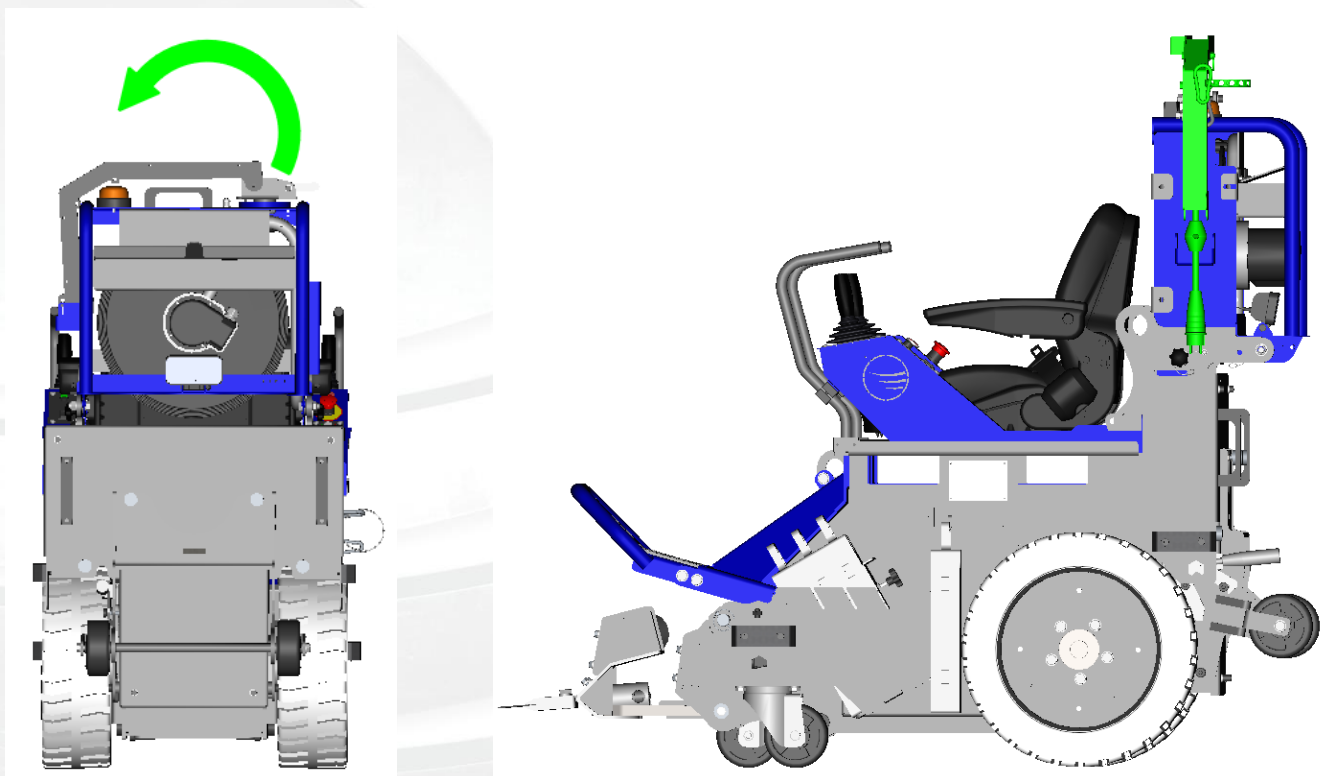

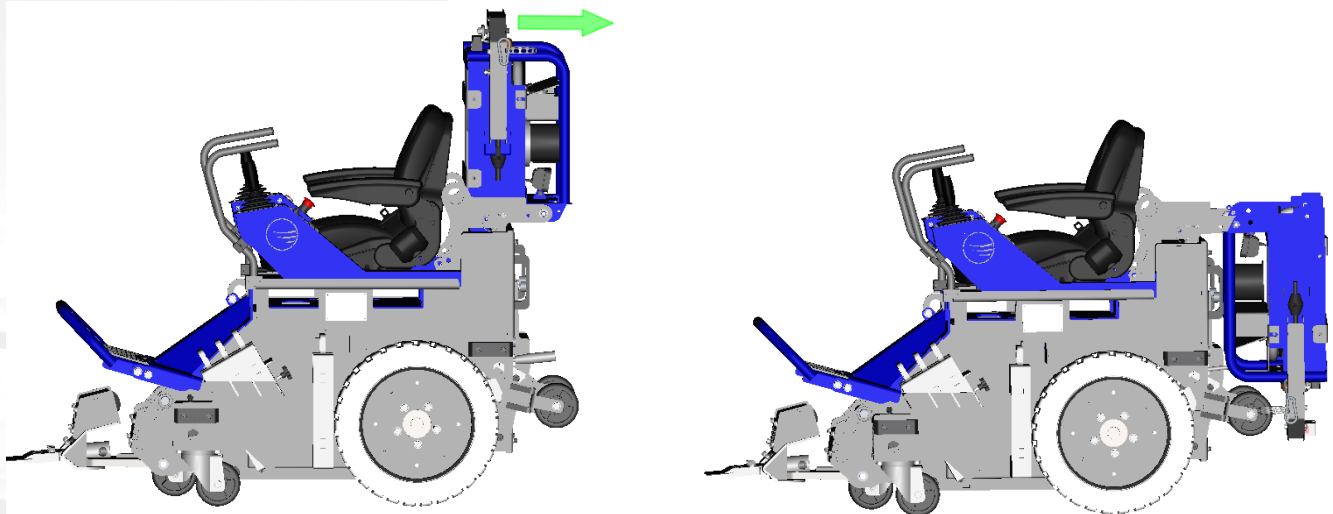
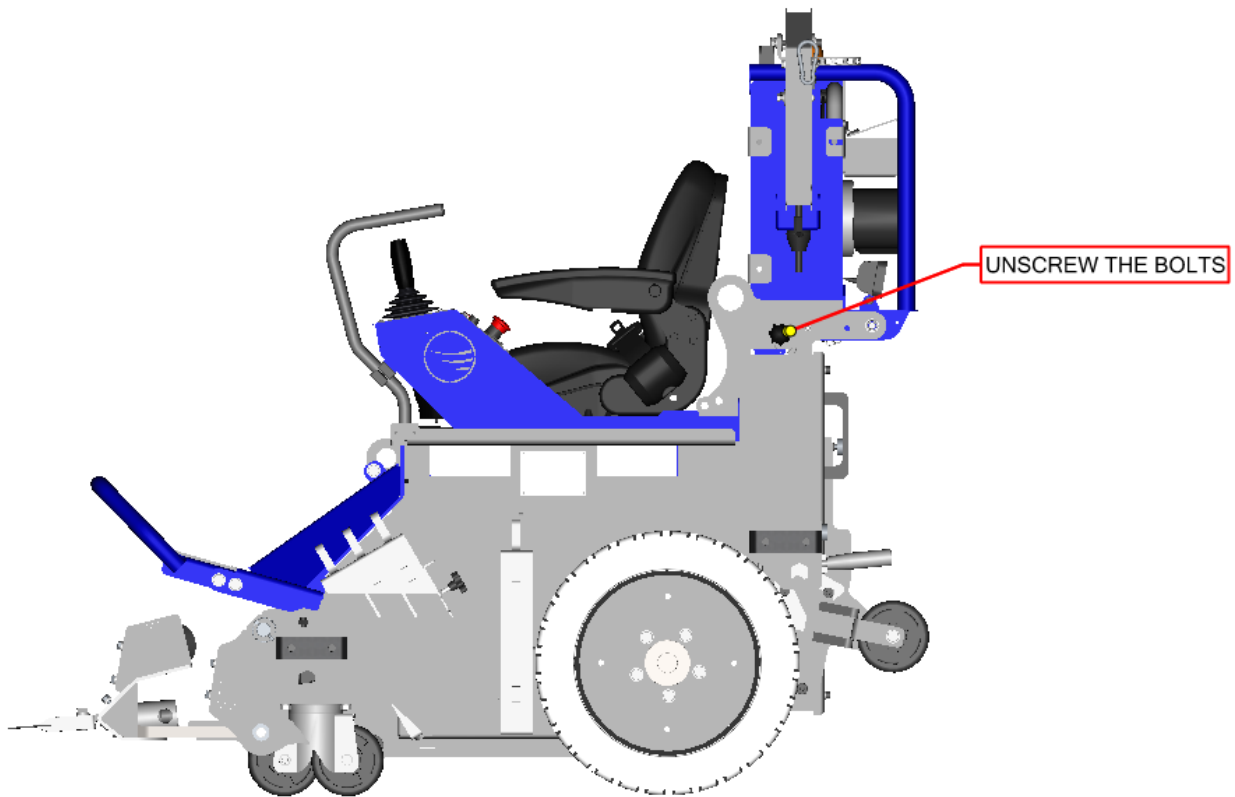
**STEP 2. Folding the cable system.**

- Screw the bolts back, to fix the cable system.



**STEP 3. Folding the Foot rest.**

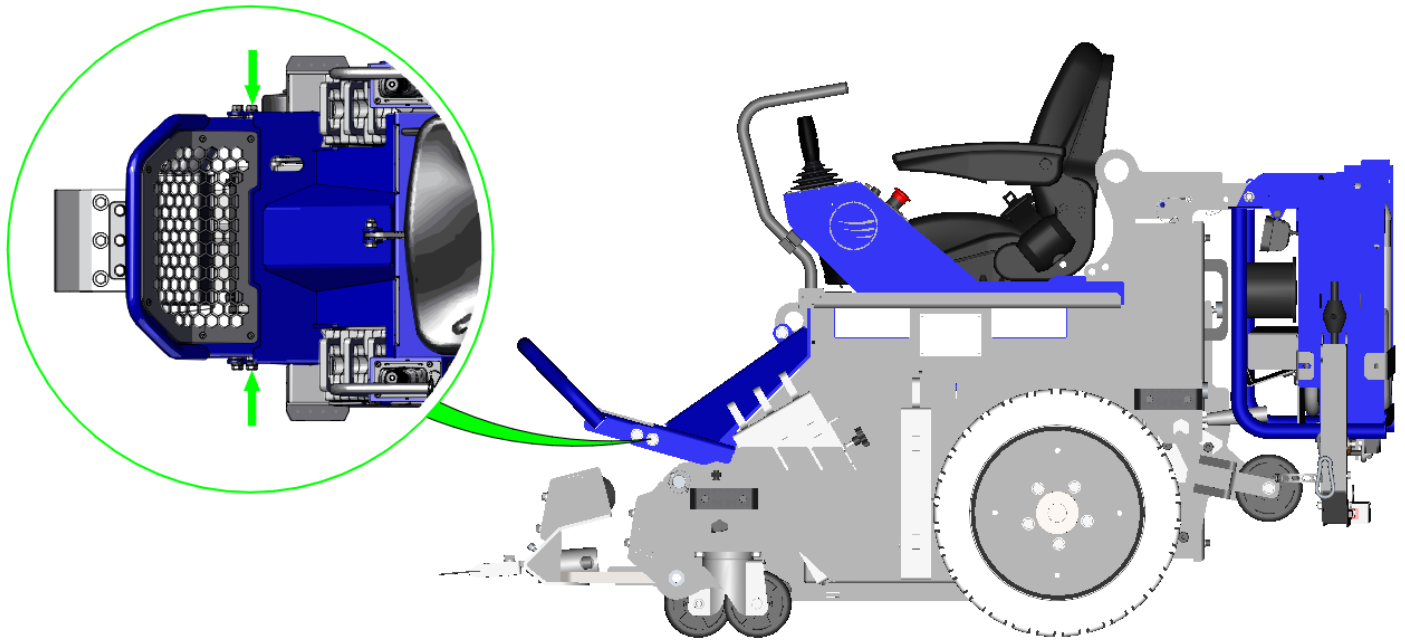

- Remove the 2 bolts, pointed by the green arrows.
- Fold the foot frame.
- Remove the tool holder.(see chapter 6.3 Blade changing)

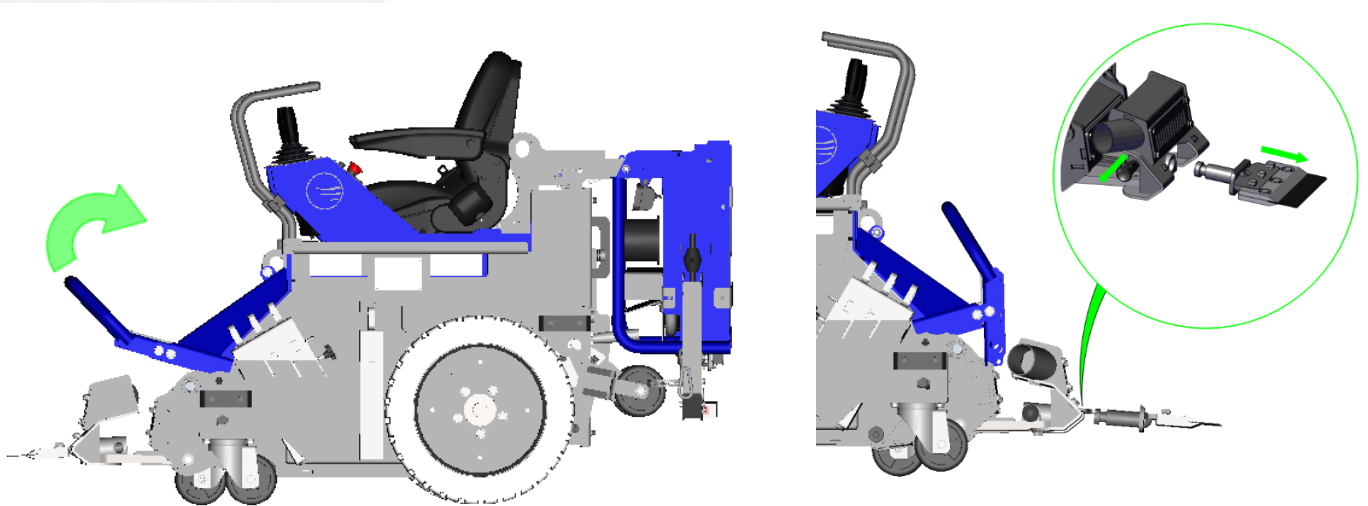



**BMS-150 FOLDED**

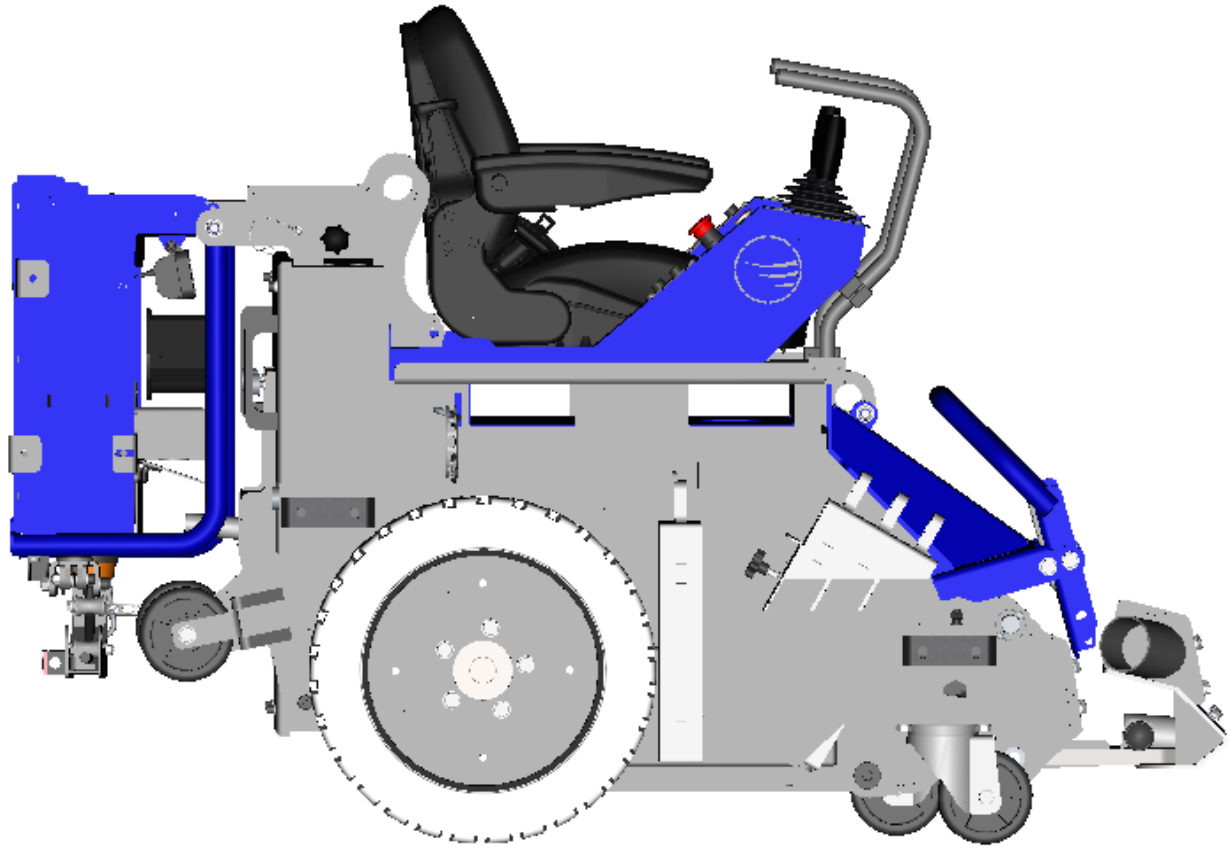



### 5.7 Start up machine

- Before start-up the operating personnel must be familiar with the safety regulations given in this manual.
- Before switching on the machine make sure that no-one can be endangered when the machine starts up.
- Persons who are not operating the machine must not be permitted to stay in the surrounding area of at least 5 meter from the machine.

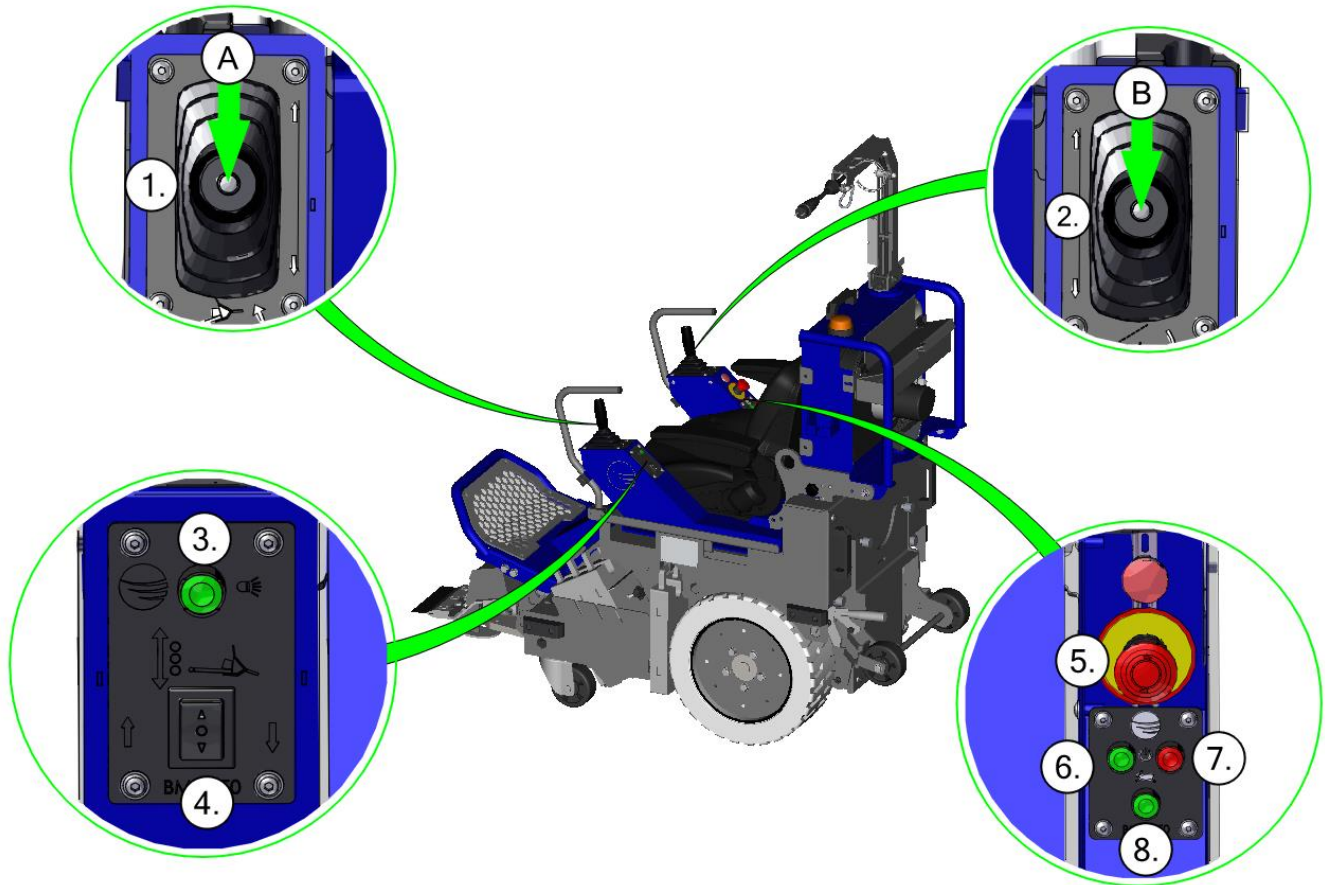

1. Check if the emergency break button is out. If not, pull the emergency break button out.
2. Plug in the main plug.
3. Press the "on" button
4. Use the joysticks to move forwards or backwards
6. Increase the speed with the Haze button.



## 6. Blades

### 6.1 Blade choice

Proper blade size and placement, depending on the material and sub-floor type, affects the performance.

Width	2"	4"	6"	8"	10"	12"	14"
	51mm	101mm	152mm	203mm	254mm	305mm	350mm
Self-Scoring Blade	E14932	E14934	E09530-1	-	-	E09533-1	-
Premium Blade	-	-	E09510	E09511	E09512	E09513	E09514
Heavy Duty Blade	-	-	E09500	E09501	E09502	E09503	E09504
Super Duty Blade	-	E14699	E14700	-	-	-	-
Premium Chisel	E09540	-	E09542	-	-	-	-
Heavy Duty Chisels	E09550	-	E09552	-	-	-	-

<b>GOOD</b>
<b>NOT RECOMMENDED</b>
<b>NO GOOD CHOICE</b>

#### Recommended blades per application

	Epoxy	Carpet	Vinyl	Wood	Tiles	PVC	Bitumen	Glue	Ceramic
Self-Scoring Blade	X	V	V	X	X	V	X	~	X
Premium Blade 1,5mm	X	V	V	X	X	V	X	V	X
Heavy Duty Blade 2,5mm	~	V	V	X	X	V	V	V	X
Super Duty Blade 4,0mm	V	V	~	~	~	~	V	~	~
Premium Chisel	V	X	X	V	~	X	X	X	~
Heavy Duty Chisels	V	X	X	V	V	X	X	X	V

#### FOR BEST PERFORMANCE:

- Start with a narrow blade, then increase the blade size to optimize the cutting pass.
  - Narrower blades work easier than wider blades, wider is not always better or faster.
  - Narrower blades usually clean the floor better.
- KEEP BLADES SHARP. Dull blades greatly reduce cutting ability. Re-sharpen or replace as needed.
- The harder a job comes up, for best results, use a smaller blade.
- Normally the bevel on the blade is up for concrete. Bevel down for soft sub-floors or wood.



- Keep your work area clean and clear of debris.
- After you have removed a portion of material, remove it out of the way. This will give the machine maximum performance and helps to keep the work area safe.
- Everyone in the work area should wear eye protection
- **Always wear cut-resistant gloves when handling blades.**





### 6.2 Working method

For soft materials like carpet, vinyl and PVC it is possible to use self-scoring blades: It's important to keep the "wings" sharp. They can be sharpened in the same way like the other blades.

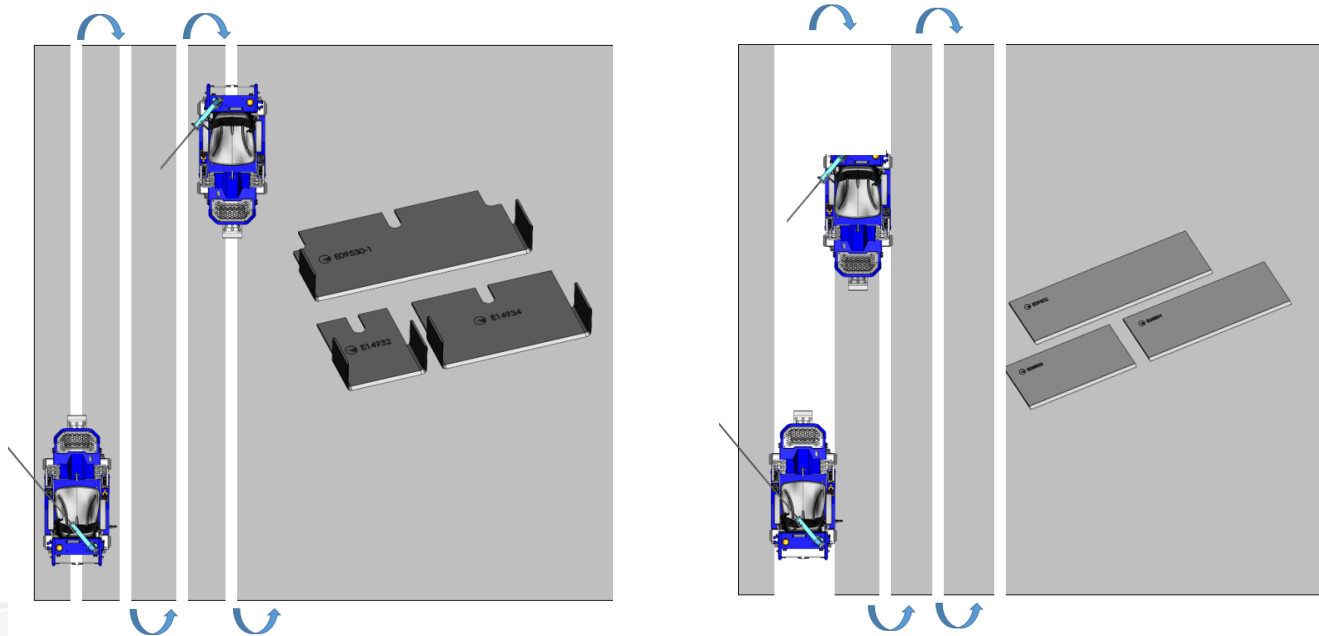

For removal of tiles and wood, it is recommended to use chisels.

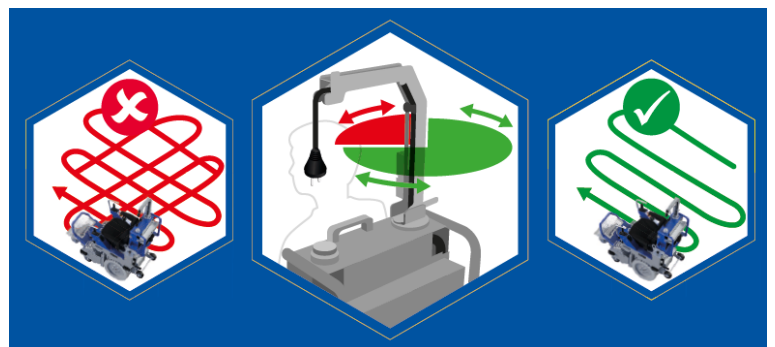
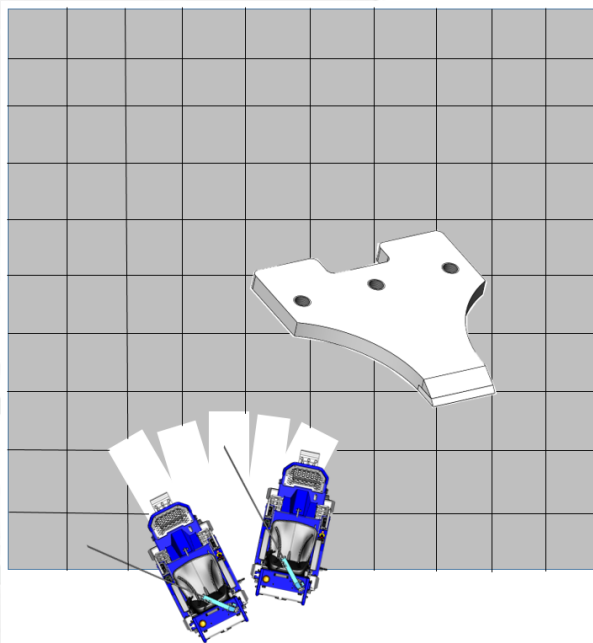

Carry out floor stripping in parallel tracks away from off the power supply in such way that the (optional) dust hose and the electrical power supply cable do not become twisted around the swivel arm. The swivel arm will not rotate 360° degree.

**Driving all around with no attention to the swivel arm will causes broken cables and swivel arms.**



### 6.3 Blade changing

Dull blades greatly reduce cutting ability. Re-sharpen or replace as needed.

- Always wear protecting cut-resistant gloves when changing the blades.
- Use an extended wrench to keep hands safely away from the edge of the blade.
- Make sure the main plug is pulled out of the power source before changing the blades.

#### Quick release pin

With the quick release pin you can easily change the blade holder.

- Step 1. Pull out the quick release pin.
- Step 2. Remove the blade holder.

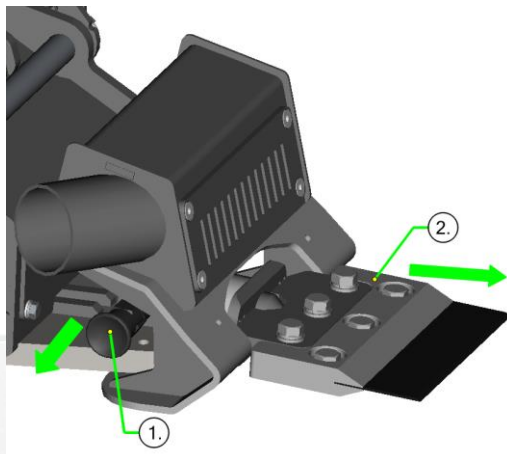

Loosen the three hexagon head bolts and replace the blade. It is not necessary to remove the bolts.



Be sure that the blade is far enough under the blade holder, to insure a secure hold.

Never leave the machine unsecured on jobsites.

When the machine is not in use for a short time, (e.g. lunch break etc.) make sure the tool cannot injure anybody.

Only change the blades if the machine is stable!





### 6.4 Cutting head & Blades

#### Cutting head angle

The cutting head is able to adjust with the "Dual lift" button (4) on the LH console. If there is no dual lift option, there are 3 positions which can be adjusted with the metal bar.

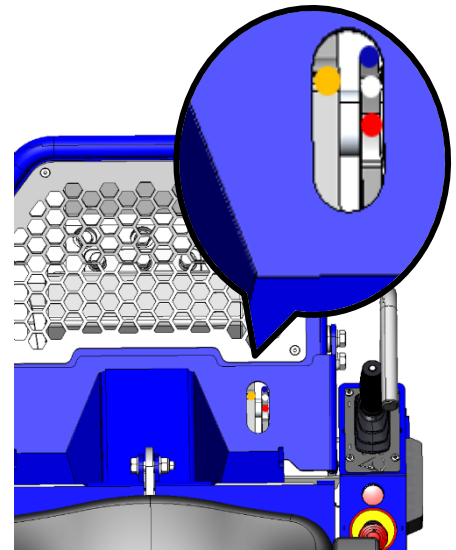
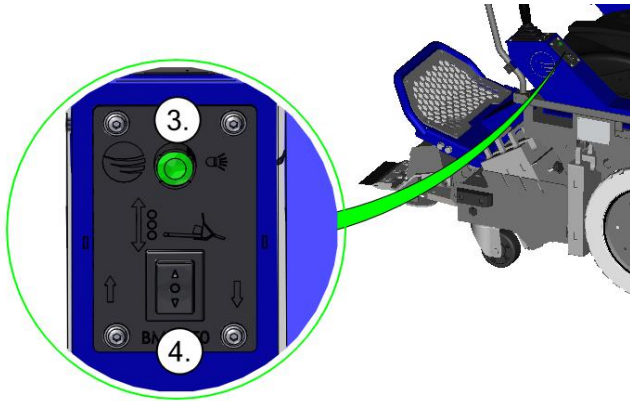

Set the cutting head angle to where the material comes up the easiest. The lowest is usually the best for most applications.

From off the operators seat you can see the height indicators.

- Orange ● - Cutting head
- Red ● - Upper position
- White ○ - Mid position
- Blue ● - Lower position

#### Steep cutting head angle

The cutting head angle can be adjusted by simply using the tool position switch. (or by the metal bar)  
 A steep angle is (mostly) only used for re-scraping. The cutting head has to be raised to its highest position. Not raising the cutting head when operating the machine at a steep angle will cause the machine to jump and buck. It does not give the operator a clear vision of the cutting head and it raises the machine to operate at an unsafe operating height.  
 Failure to raise the cutting head could cause machine damage and/or bodily injury.

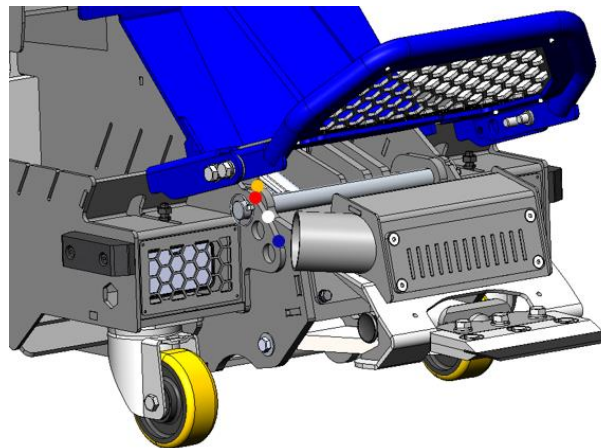
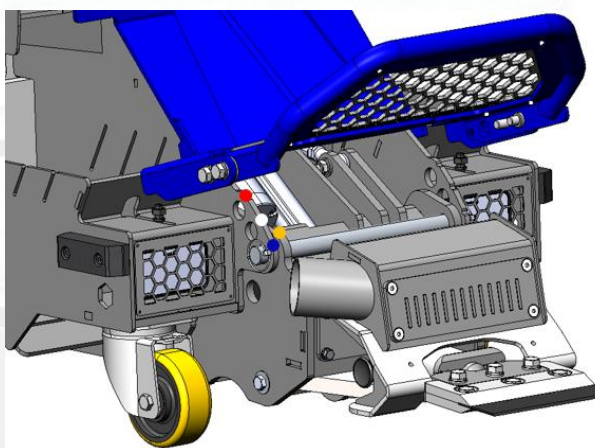





## 6.5 Blade sharpening

**Always wear protecting, cut-resistant gloves and safety glasses.**

It is not necessary to remove the bolts. Sharpen the blade mounted to the machine using a hand grinder. Sharpen the blade with a 10 cm diameter disk with 120 or finer grit.

**WARNING! Be careful, make sure the disc does not catch the edge or corner of blade.**

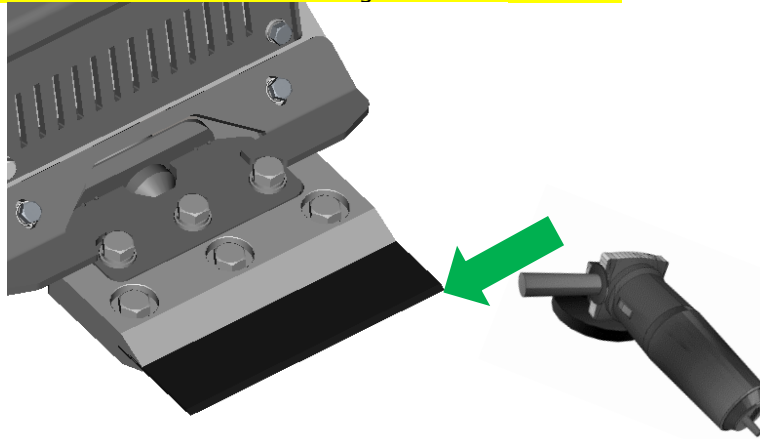

Furthermore, there is the opportunity to remove the blade from the machine and to sharpen the blade at a vice, obeying the same way as shown in figures above.

### **Weight vs. sharpness**

The most common way to compensate for a dull blade is to add more weight and raise the blade angle (see re-scrape setting). Weight allows dull blades to be used to a point.

Weight also causes blades to dull and break easier. Blades of any thickness tend to catch cracks and expansion joints and will bend or break the blade if set at a high angle.

For best results, run a small ditching blade at a low angle to identify as many cracks and joints as possible. If blades are breaking, the conditions are misunderstanding.

### **Blade application**

Important is to understand that when the blades are breaking, some of the conditions of usage or settings are not correct. In many cases the angle between tool and ground can't be too big because the machine can jump and even takeover to the back. Always try different blades and cutting head angles for best performance

### **Swiveling tool holder (#E14797)**

The swiveling tool holder keeps the blade in contact with the floor even when the floor is uneven. When using a flat blade, by swiveling the head over 180° allows you to use the other sharp edge on the blade without having to replace the blade.

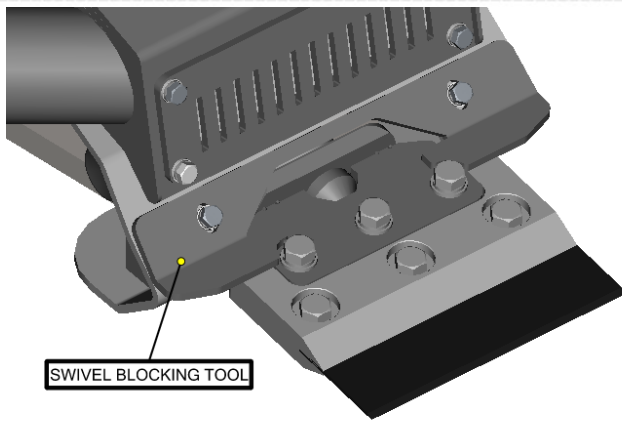

SWIVEL BLOCKING TOOL

### **Saving time with extra blades, blade holders and tool holders**

The machine is supplied with one tool holder. Having additional tool holders, blade holders and blades will save time on the job. When the blade is dull, instead of taking the time to replace it or sharpen it on the job, replace it with another prepared set.

Or, when a different type or size of blade is needed, you have them ready to use.

Having a second tool holder will be helpful, and it **will save you important time and money.**





## 6.6 Types of tear outs

Keep blades sharp! Keep your work area clean and clear of debris.

**Always wear personal Protective equipment when working with the machine.**

### **VCT – Vinyl Composition Tile**

***[Super duty or Chisel]***

Never use a blade wider than the size of the tile being removed.

If goods being removed still do not come up clean or the machine jumps on top of goods, reduce blade size to a smaller blade until proper blade size is found or use a smaller portion of the blade.

### **Vinyl-, Rubber, PVC, Direct glued carpet**

***[Self-Scoring & Premium/Heavy Duty/Super Duty]***

Goods will need to be scored down to 254 to 305 mm for proper removal with self-coring blade 2"/4"

Pre-scored carpet makes the machine easier to control and blades stay sharper longer. Blades up to 254 cm wide can be used. Normally 203 mm blades are used on direct glued carpet, secondary backed, unitary, double glued, vinyl foam, urethane foam. Latex foams come up easily with a wider blade.

Self-scoring blades can be used with some materials. A 102 mm blade is recommended for this product, but determine what size blade works best.

### **Ceramic (glued with double duty or mud sets)**

***[Heavy dusty chisel]***

Before removing ceramic tile, tiles will have to be pre-broken with a mallet or large hammer. On small random block styles of tile, pre-breaking may not be necessary.

Open an area large enough for machine or blade to fit in, or start from a doorway. Keep work area clean to keep good wheel contact with floor. Use slow speed and small blades.

Blades can be offset in cutting head for easier access to toe kicks or removal along the wall.

### **Glued hard wood flooring**

***[Super Duty or Chisels]***

A 104 mm Super Duty blade is recommended for regular adhesive, a 51 mm chisel for epoxy.

For proper removal of hardwood flooring (plank solid, plank laminated, parkay, parquetry laminated) flooring must be scored to blade width.

This is done by using a circular saw set at a depth of 99% of the thickness of the board, just missing the subfloor surface when on concrete

A chalk line for scoring lines can be used across the floor the width of the blade

True parky flooring scoring is not necessary. It will come up in small pieces.

When working over plywood sub-flooring, try to run machine in the same direction as the grain in the wood. Blade in most cases bevel down. On solid wood floors like plank, run in the same direction as the plank, not cross grain or cross plank. Removing the front counterweights will help on all soft surfaces.



## 7. Maintenance

Pay attention to Chapter 3 "**General Safety Rules**" during maintenance and repair works.

Failures due to inadequate or incorrect maintenance may generate very **high repair costs** and long standstill periods of the machine. **Regular** maintenance therefore is imperative. Also with proper maintenance the machine will produce less hand- arm transmitted vibrations.

Operational safety and service life of the stripper depends, among other things, on proper maintenance.

The following table shows recommendations about time, inspection and maintenance for the normal use of the stripper.

### - BMS-150

Operating hours/ time period	Inspection points, maintenance instructions
12 h after repairing	Check all accessible screw connections and other fasteners for tight seat.
Daily and prior to starting work	Check that all safety devices are working adequate. Check the function of the residual current operated device. Check the blades for wear and sharpness. Check the electric connections for sediments of dirt or foreign bodies. Check the electric motors for dirt and other contaminants.
Weekly	Check the conditions and tightness of the connections of the frequency drive. Remove any dust from the frequency drive. Ensure proper fan operation of: the frequency drive and drive motor. Check for physical damage to the covers of the: the frequency drive and drive motor.
Annually	Full overhaul and cleaning of the complete machine.

### - Electrical cable and reel.

Operating hours/ time period	Inspection points, maintenance instructions
Regularly (at least once a year)	Check that the cable is intact. Clean the cable if it is oiled or dirty. Check the spring function by testing if the cable recoils properly. Adjust if necessary.

The time indications are based on uninterrupted operation. When the indicated number of working hours is not achieved during the corresponding period, the period can be extended. However a full overhaul must be carried out at least once a year.

Due to different working conditions it can't be foreseen how frequently inspections for wear check's, inspection, maintenance and repair works ought to be carried out. Prepare a suitable inspection schedule considering your own working conditions and experience.

Our specialists will be happy to assist you with more advice.

**Prior to any repair works on the machine and its drives, secure the machine against unintentional switching on. Make sure the main plug is pulled out of the power source.**

**Follow additional operating and maintenance instructions of Original Equipment Manufacturers if included during your service and maintenance work.**



**Further is advised:**

Store the cleaned and dry machine in a dry and humid free room. Protect the electrical motors from moisture, heat, dust and shocks.

All repair work must to be done by qualified Blastrac personnel, this to guarantee a safe and reliable machine.

Any guarantee on the machine expires when:

- Non original Blastrac parts have been used
- Repair work is not done by qualified Blastrac personnel

Changes, add one's or conversions are undertaken without written permission from Blastrac BV.



### 7.1 Trouble shooting.

Fault	Possible cause	Remedy
BMS-150 does not switch on	Electrical protection cable switch is activated.	Put the key of the electrical switch in.
	<ul style="list-style-type: none"> <li>- Plug is out of the main power supply.</li> <li>- Thermal overload protector of the cable reel is on.</li> <li>- BMS-150 switches off after 15 seconds of inactivity.</li> </ul>	<ul style="list-style-type: none"> <li>- Put the plug back in the power supply.</li> <li>- Reset the thermal overload protector.</li> <li>- Start BMS-150 up again.</li> </ul>
	Defective Component.	<ul style="list-style-type: none"> <li>- Find fault and replace defective component. (Chapter 7.1).</li> <li>- Open the electrical cover and check the fault code.</li> <li>- If the problem cannot be solved, write down the fault code and contact your local Blastrac dealer.</li> </ul>



- Pull out the transport bracket

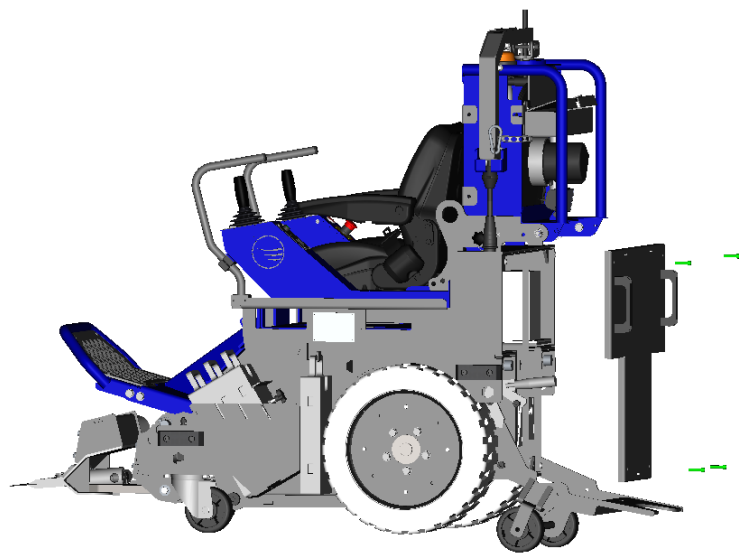
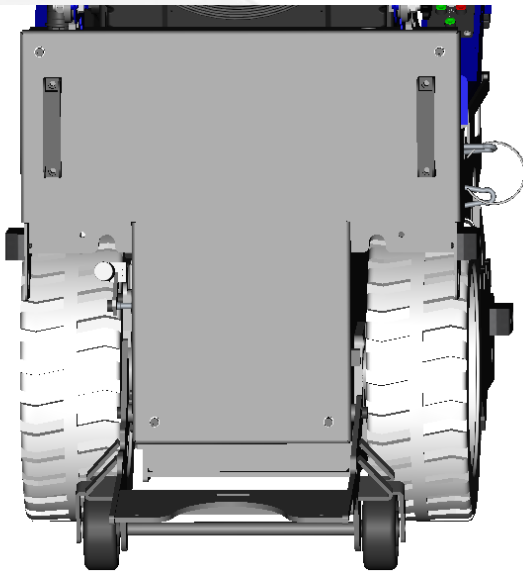
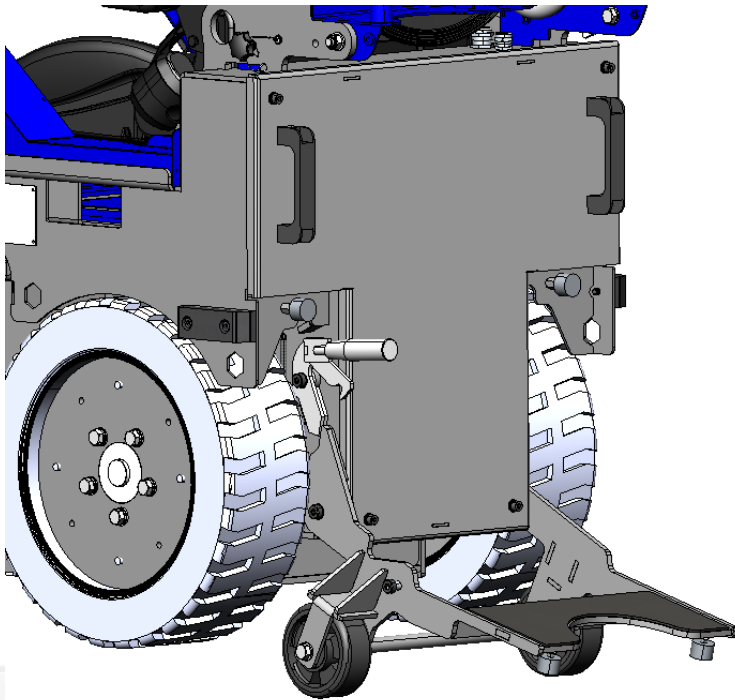

- Unscrew the 4 bolts.



- Check the FAULT CODE.

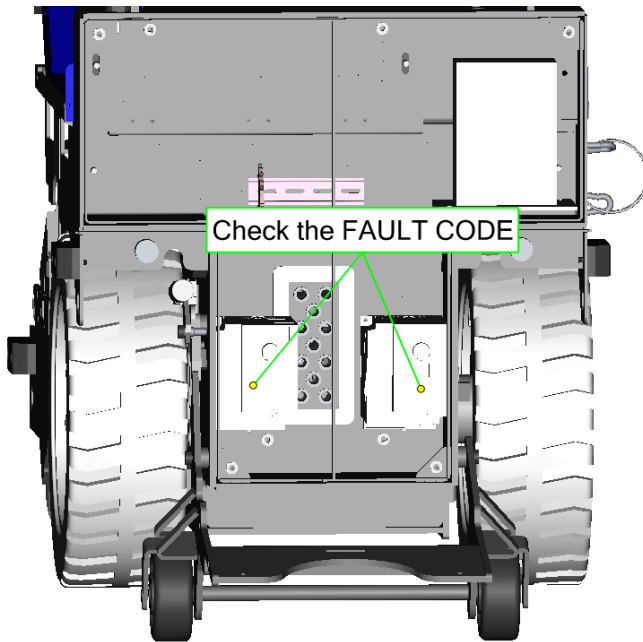

### Most Common Fault codes

Detected Fault	Name	Probable cause	Remedy
√SF	Under voltage	<ul style="list-style-type: none"> <li>- Supply mains too low</li> <li>- Voltage dip</li> </ul>	<ul style="list-style-type: none"> <li>- Check the voltage</li> </ul>
□SF	Over voltage	<ul style="list-style-type: none"> <li>- Supply voltage too high.</li> <li>- Disturbed main supply</li> </ul>	<ul style="list-style-type: none"> <li>- Check the supply voltage</li> </ul>
□PF2	3 motor phase loss	<ul style="list-style-type: none"> <li>- Motor not connected or motor power too low.</li> </ul>	Check the connections from the drive to the motor
SCF5	Motor short circuit	<ul style="list-style-type: none"> <li>- Short-circuit at drive output.</li> </ul>	<ul style="list-style-type: none"> <li>- Check the cables connecting to the motor, and the motor's insulation.</li> </ul>

**Note: If the problem cannot be solved or another fault code appears, write down the fault code and contact your local Blastrac dealer.**



## 8. Technical data

<b>BMS-150</b>	
Drive motor power	1,1 kW (220V) per motor 0,55 kW (110V) per motor
Drive speed Max.	Up to 40 m/min
Application	Hard Wood parquet / ceramics / linoleum / vinyl / carpet / adhesives / glue / tiles etc...
Working position	
Length (L)	1475 mm
Width (W)	716 mm
Height (H)	1750 mm
Folded position	
Length (L)	1580 mm
Width (W)	716 mm
Height (H)	1092 mm
Weight	480 kg (without weights) 595 kg (incl. weight kit) 680kg (incl. weight kit and wheel weights)
Environment	Temperature range from (14 to 104°F) or (-10 to 40°C) Relative humidity of max. 95%

The electrical diagrams of the electrical system are placed inside of the control panel.  
Design and specifications are subject to change without notice by Blastrac B.V.

The BMS-150 230V can be used in 50hz and 60 Hz.

### 8.1 Dimensions of the machine

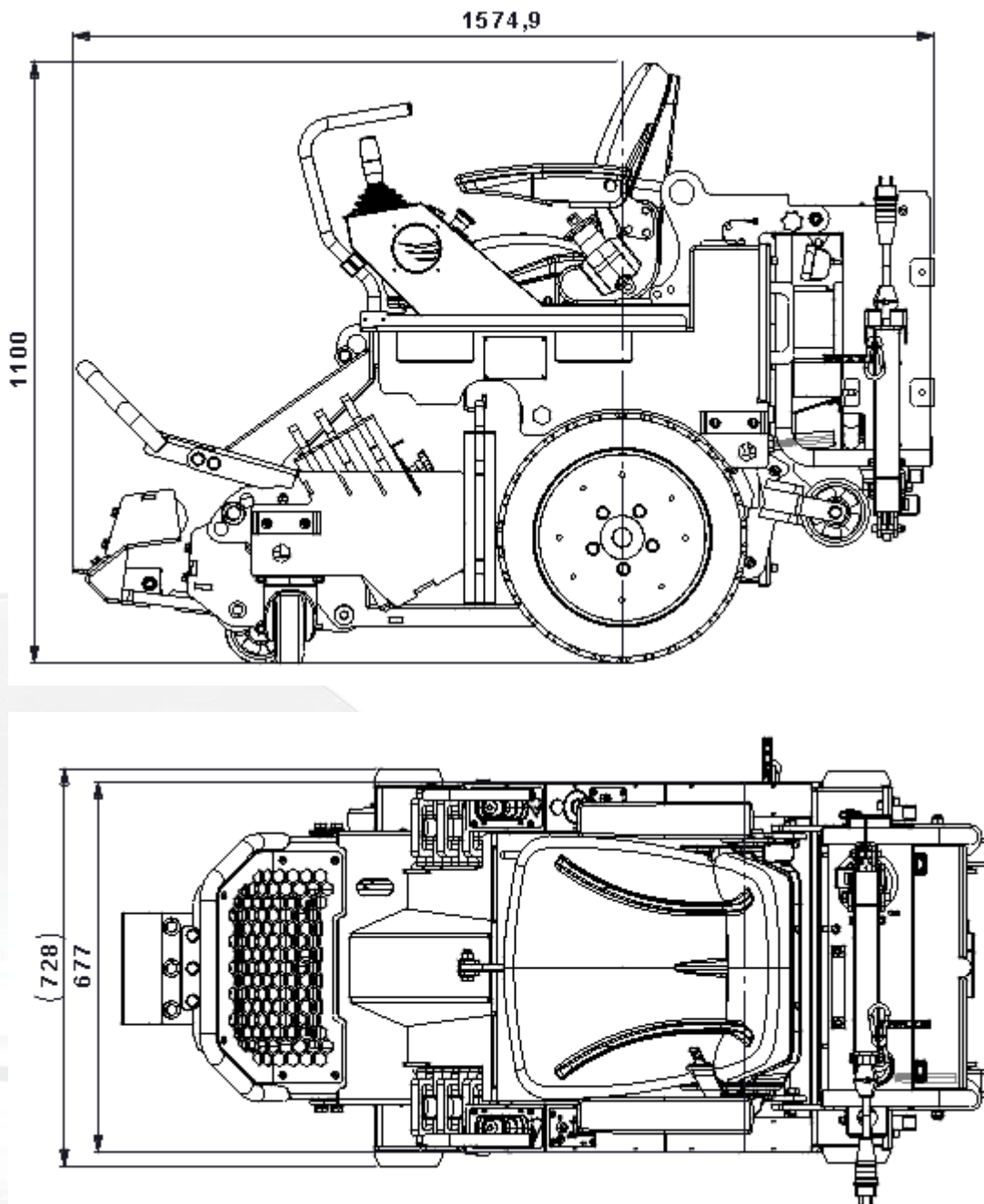

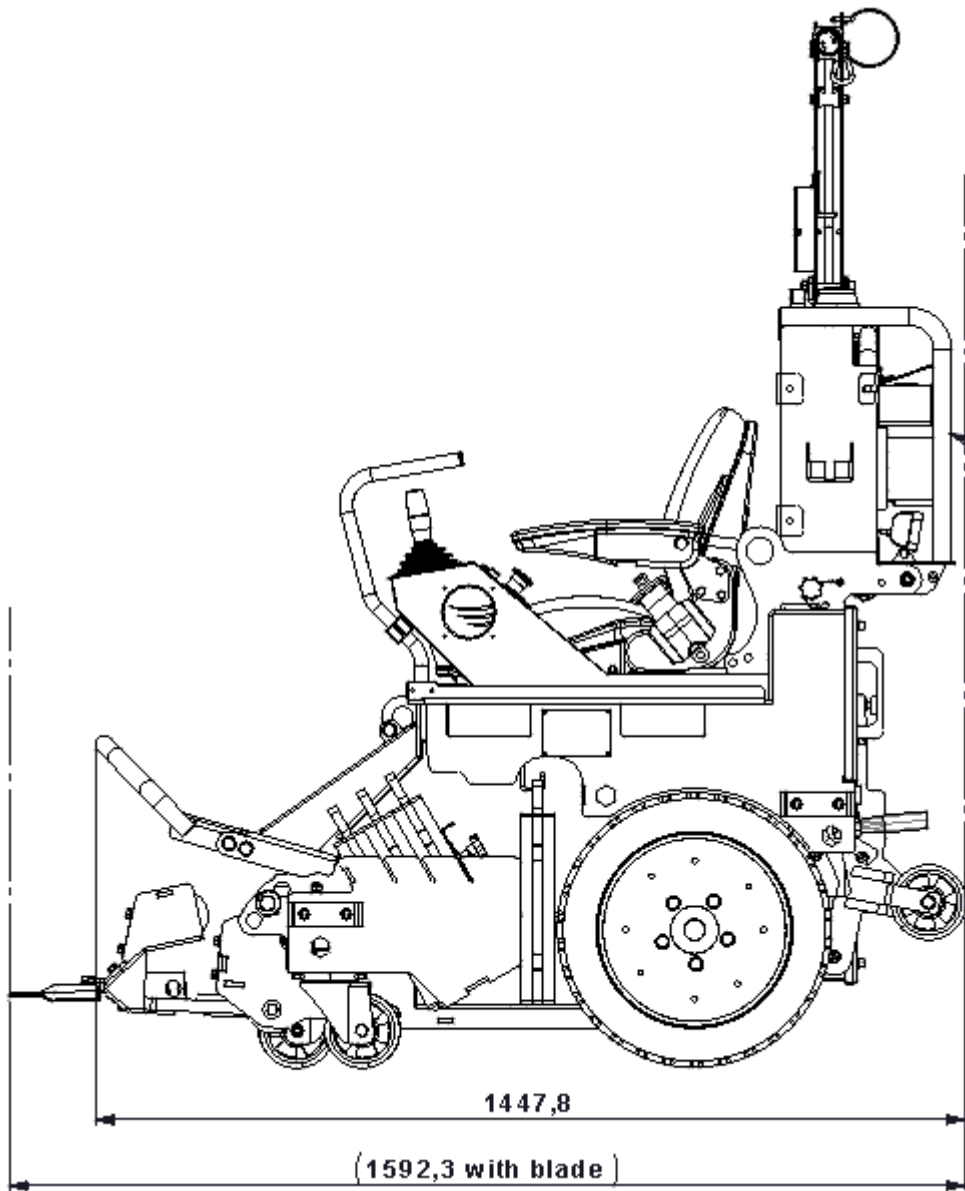



## 8.2 Sound and vibration data

**Sound level:** 77 dB(A) relative to 20 $\mu$ Pa.

Ear protection is recommended with the use of this equipment.

### Vibration level:

Declared hand- arm vibration emission in accordance to EN 12096

The total vibration value to which the hand-arm system is subjected, does not exceed 2,5 m/s<sup>2</sup>.

Vibration test code EN-ISO 20643

The total vibration value to which the whole body is subjected, does not exceed 0,5 m/s<sup>2</sup>.

Uncertainty  $K = 0,1 \text{ m/s}^2$

Surface: smooth concrete

Declaration in conformance with EN 12096: 1997

Measurement in conformance with EN-ISO 2631-1 and EN 1032 as far as applicable.

*The measurements of the sound and vibration level are taken from a similar machine within the Blastrac company.*

### IMPORTANT NOTES:

The measurement are from a similar machine

The indicated values are measured on new machines. Noise and vibration levels will vary in different circumstances. Area influences like open outside or closed inside space, ambient temperature, different surfaces to be treated, daily use, different tools or accessories, poor maintenance, etc. will give different values at all time and could increase the exposure level over the total working period.

The declared vibration and noise emission levels represent the main applications of the machine. The values may be measurements from a representative sample of technically comparable machinery. The values may be used for a preliminary assessment of exposure.

A precise estimation of the level of exposure to vibration and noise should also take in account the times when the machine is switched off or even running, but not actually in use. This may significantly decrease the exposure level over the total working period.

Identify additional safety measures to protect the operator from the effects of vibration and noise such as: proper and regular maintenance of the machine and the accessories, keeping the hands warm, organization of work patterns for example by using rotation schedules. The use of anti-vibration gloves could also decrease the effects of the vibrations transmitted.

Although the sound pressure level at the operators position does not exceed 80 dB(A), ear protection is still strongly recommended when working with this machine.





### 8.3 Options

Extra weight kit, placed on both sides.  
Total amount of weight: 115 kg

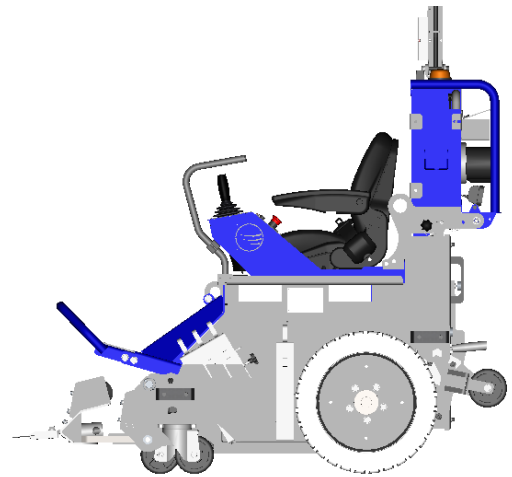
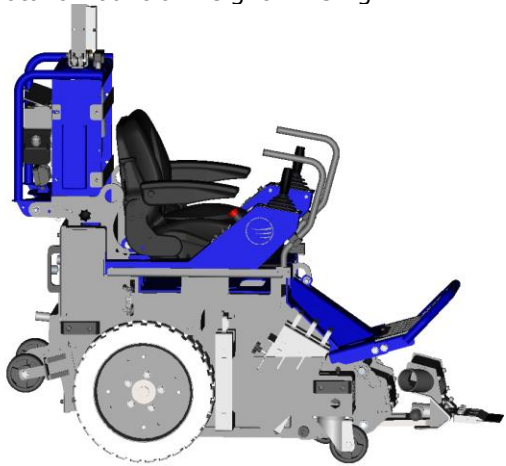

#### STEP 1.

3 extra weights can be placed on each side.

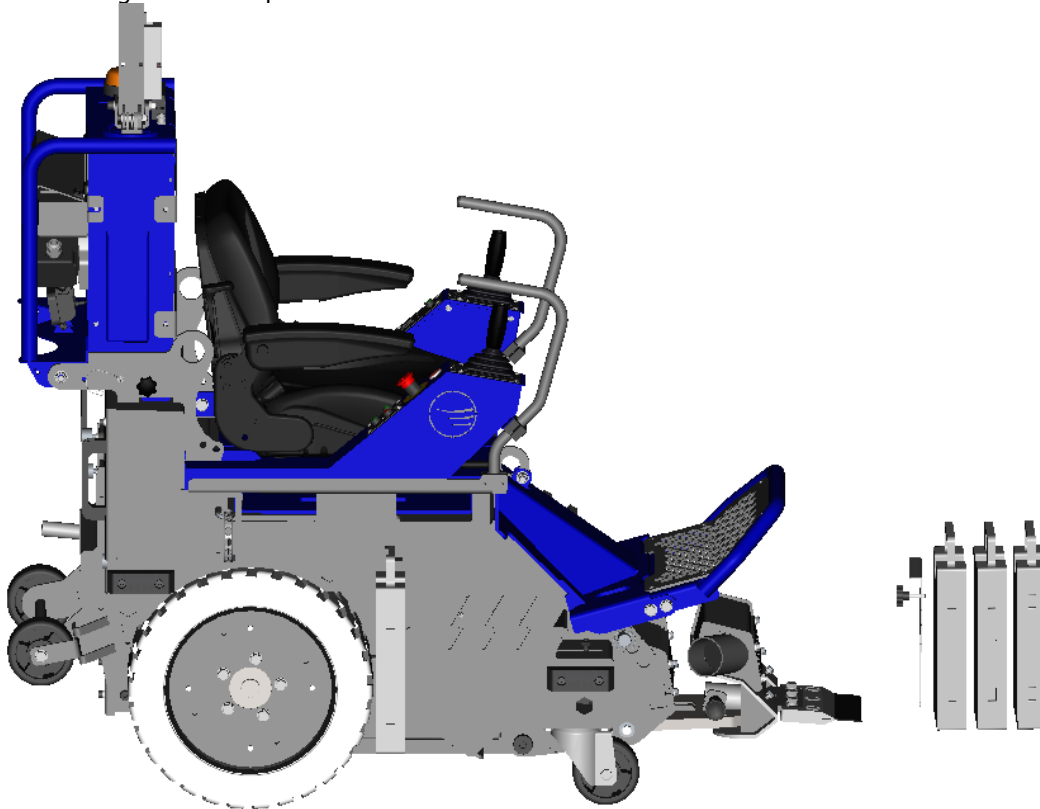



**STEP 2.**

Place one extra weight part at the time.

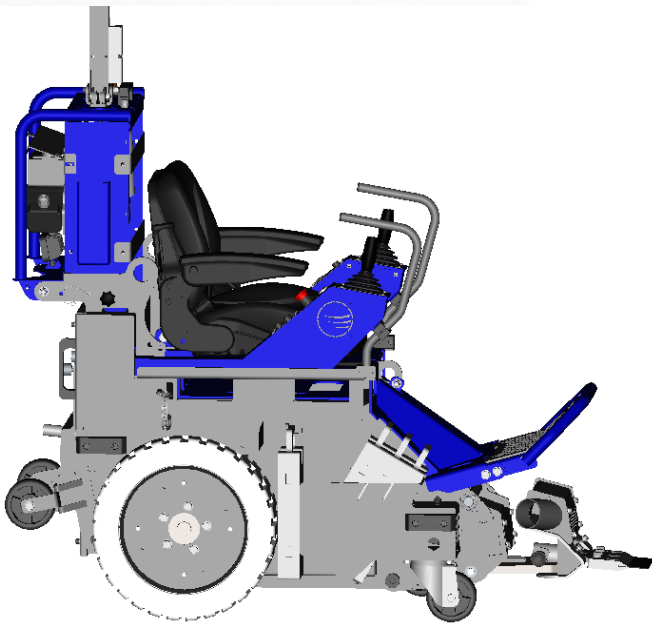
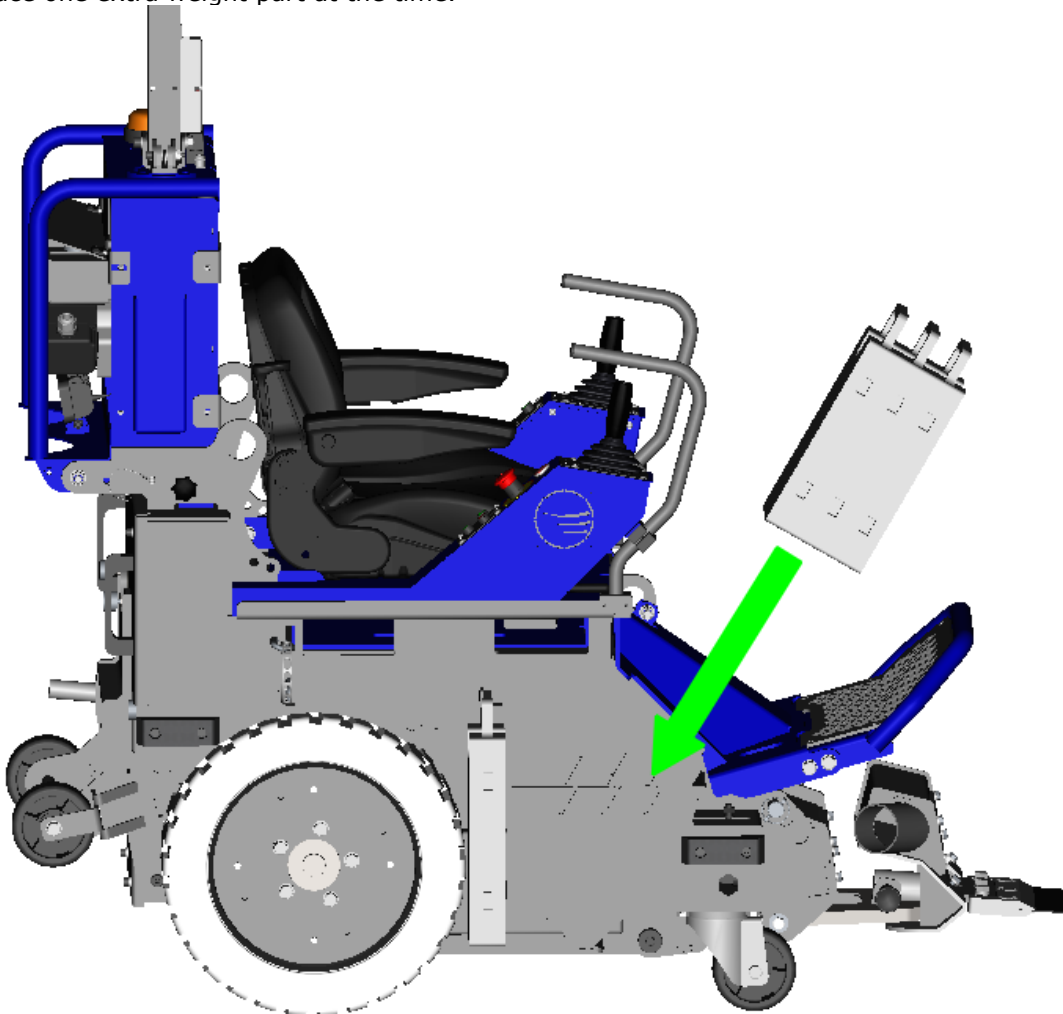

**STEP 3.**

Place the weight lock.

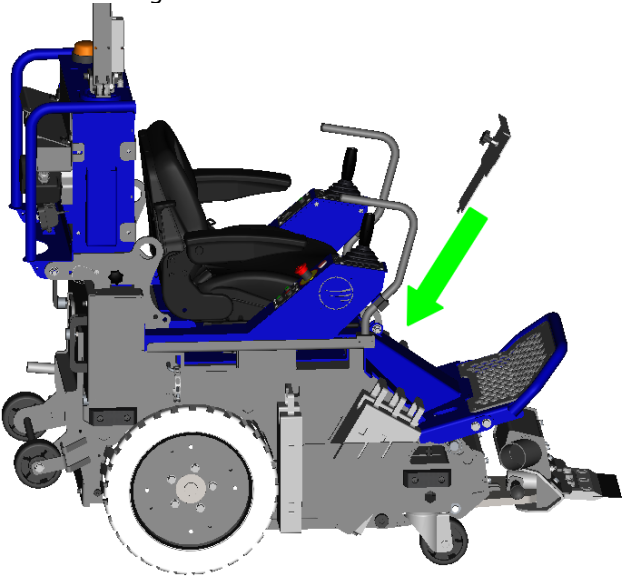
**STEP 4.**

Secure the extra weight parts with the weight lock by screwing the knob.

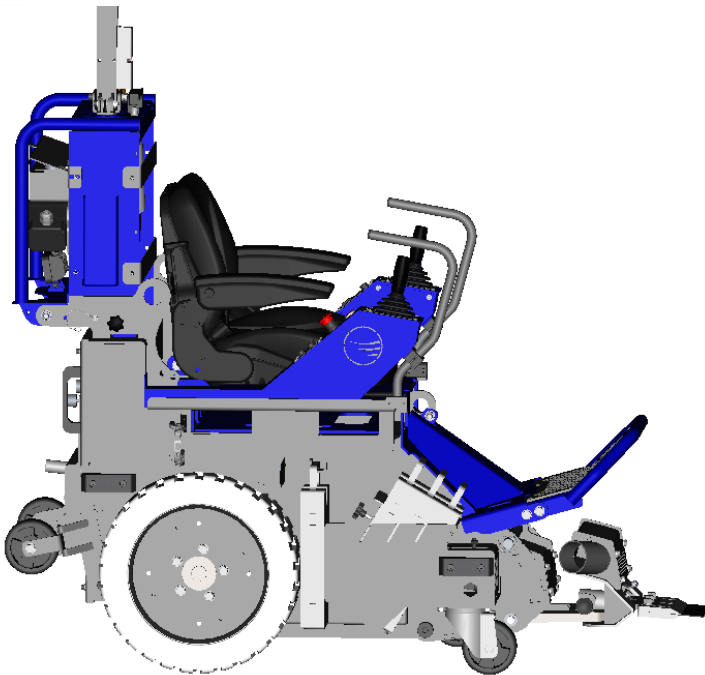



Extra wheel weight kit, placed on both wheels.  
Total amount of weight 85 kg (10x8,5 kg)

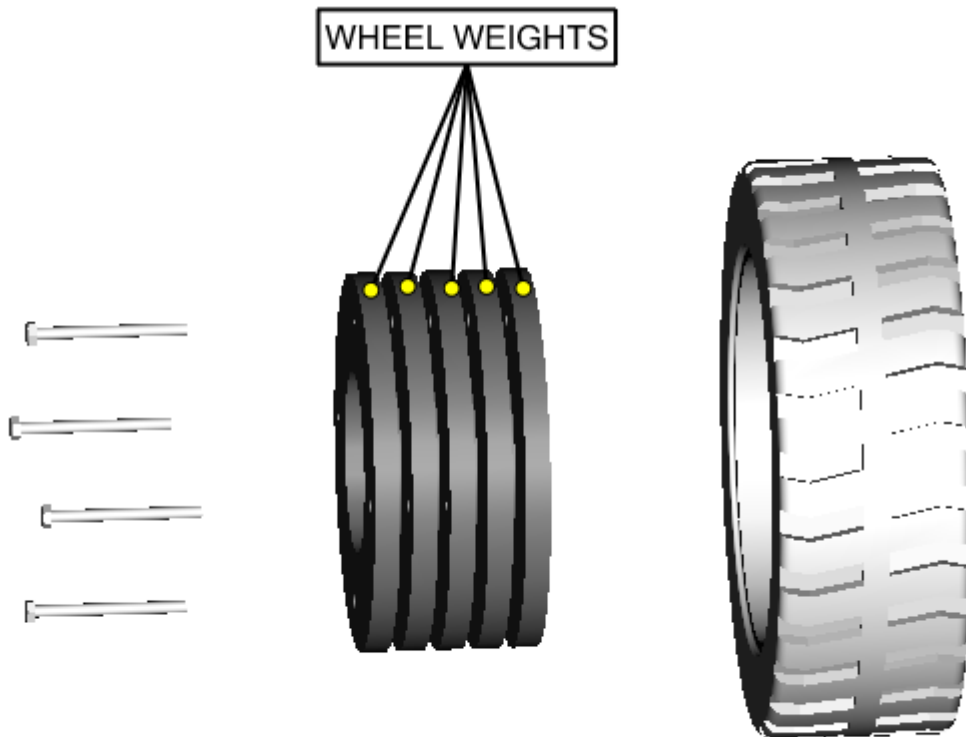

- Use 5 pieces on each side.

#### STEP 1.

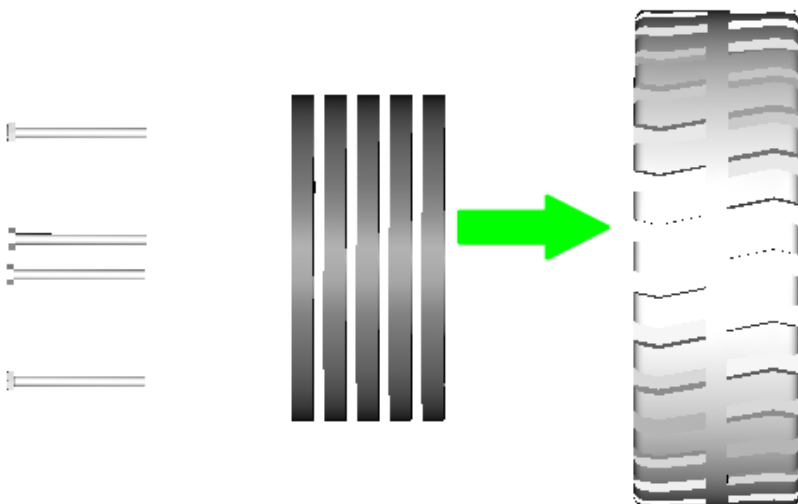

- Place the 5 pieces inside the wheel

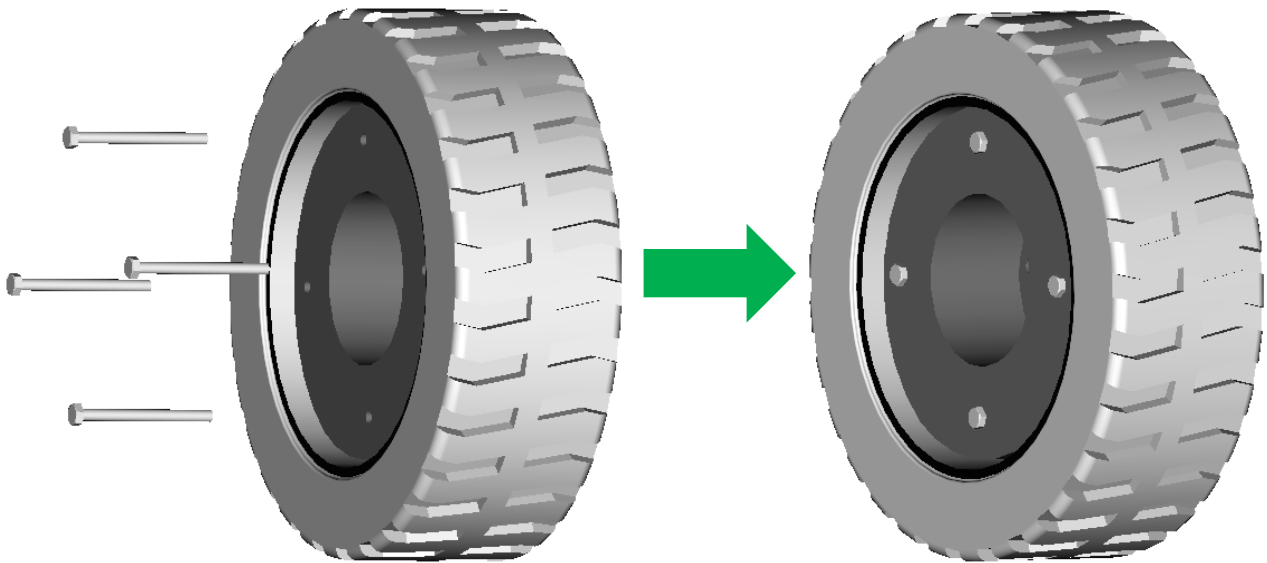

**STEP 2.**

- Mount the extra wheel weights. Using 4x M10 x 120 bolts, use loctite 243.

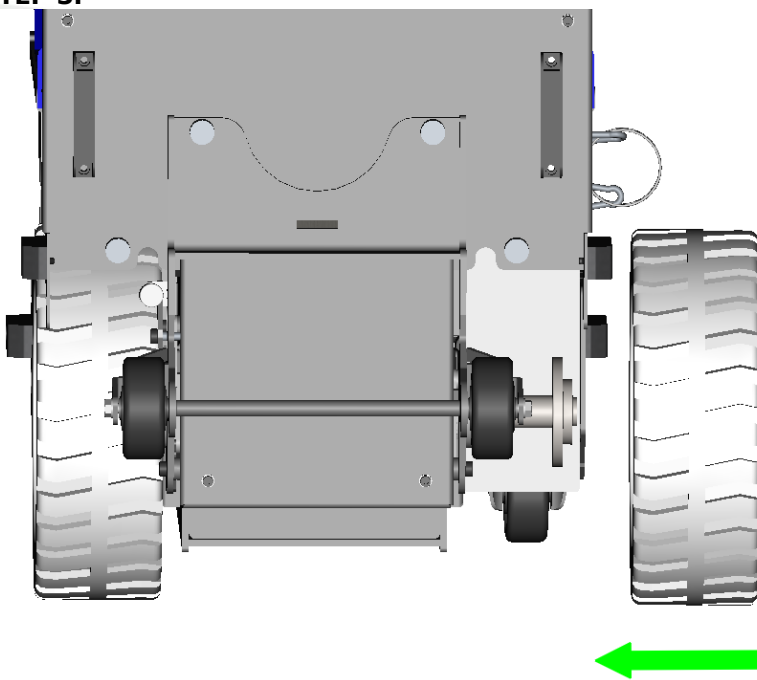
**STEP 3.**

- Mount the wheel back. Using 5x M12 x40 mm, lock washer and plain washer. Use loctite 243.



## BLASTRAC EUROPE

WE'RE READY TO ASSIST YOU!

### BLASTRAC THE NETHERLANDS

EUROPEAN HEAD OFFICE  
Utrechthaven 12  
NL - 3433 PN Nieuwegein  
Tel.: +31 (0)30 601 88 66  
Fax: +31 (0)30 601 83 33  
Email: [info@blastrac.nl](mailto:info@blastrac.nl)  
[WWW.BLASTRAC.EU](http://WWW.BLASTRAC.EU)

### BLASTRAC POLAND

SALES & SERVICE CENTRE  
Golina, ul. Dworcowa 47E  
63-200 Jarocin  
Tel.: +48 (0)62 740-41-50  
Fax: +48(0)62 740-41-51  
Email: [info@blastrac.pl](mailto:info@blastrac.pl)  
[WWW.BLASTRAC.PL](http://WWW.BLASTRAC.PL)

### BLASTRAC FRANCE

SALES & SERVICE CENTRE  
ZI - 29, Av. des Temps Modernes  
F - 86360 Chasseneuil du Poitou  
Tel.: +33 (0)5 49 00 49 20  
Fax: +33 (0)5 49 00 49 21  
Email: [info@blastrac.fr](mailto:info@blastrac.fr)  
[WWW.BLASTRAC.FR](http://WWW.BLASTRAC.FR)

### BLASTRAC ITALY

SALES & SERVICE CENTRE  
S.S. 10 Padana Inferiore, 41  
IT - 29012 Caorso (PC)  
Tel.: +39 0523 814241  
Fax: +39 0523 814245  
Email: [info@blastrac.it](mailto:info@blastrac.it)  
[WWW.BLASTRAC.IT](http://WWW.BLASTRAC.IT)

### BLASTRAC GERMANY

SALES & SERVICE CENTRE  
Richard-Byrd-Str. 15  
50829 Köln  
Tel.: +49 (0) 221 709032-0  
Fax: +49 (0) 221 709032-22  
Email: [info@blastrac.de](mailto:info@blastrac.de)  
[WWW.BLASTRAC.DE](http://WWW.BLASTRAC.DE)

### BLASTRAC UKRAINE

SALES & SERVICE CENTRE  
Nezalezhnosti 14, of. 21  
07400 Brovary  
Tel.: +38 (0)44 222 51 28  
Fax: +38 (0)44 277 98 29  
Email: [info@blastrac.com.ua](mailto:info@blastrac.com.ua)  
[WWW.BLASTRAC.COM.UA](http://WWW.BLASTRAC.COM.UA)

### BLASTRAC SPAIN

SALES & SERVICE CENTRE  
Calle del Estío, 9  
E - 28500  
Arganda del Rey, Madrid  
Tel.: +34 91 660 10 65  
Fax: +34 91 672 72 11  
Email: [info@blastrac.es](mailto:info@blastrac.es)  
[WWW.BLASTRAC.ES](http://WWW.BLASTRAC.ES)

### BLASTRAC UNITED KINGDOM

SALES & SERVICE CENTRE  
Unit 2a, Outgang Lane, Dinnington  
Sheffield, South Yorkshire  
GB - S25 3QY  
Tel.: +44 (0) 1909 / 569 118  
Fax: + 44 (0) 1909 / 567 570  
Email: [info@blastrac.co.uk](mailto:info@blastrac.co.uk)  
[WWW.BLASTRAC.CO.UK](http://WWW.BLASTRAC.CO.UK)

### BLASTRAC MIDDLE EAST

SALES & SERVICE CENTRE  
P.O. box 29424  
Dubai / United Arab Emirates  
Tel.: +971 4 3245760  
Fax: +971 4 3245761  
Email: [info@blastracdxb.ae](mailto:info@blastracdxb.ae)  
[WWW.BLASTRAC.AE](http://WWW.BLASTRAC.AE)

### BLASTRAC NORDIC

SALES & SERVICE CENTRE  
Lekstorps Industriväg 13D,  
443 41, Gråbo  
Sweden  
Tel.: +46 (0) 31 30 333 55  
Email: [info@blastrac.se](mailto:info@blastrac.se)  
[WWW.BLASTRAC.SE](http://WWW.BLASTRAC.SE)

### BLASTRAC INDIA

SALES & SERVICE CENTRE  
G.B. Warehousing, GAT NO- 523,  
Pune- Nagar Road, Wagholi  
Pune- 412 207  
Tel.: +91 99213 98109  
Email: [info.blastrac.in](mailto:info.blastrac.in)  
[WWW.BLASTRAC.IN](http://WWW.BLASTRAC.IN)