



Eng Operator's manual & spare parts list.

It is the owner's responsibility to ensure that all operators of this machine have read and understood the content of this manual before using the product! Careless or improper use of this machine can cause serious or even fatal injury! Allow only competent adults to operate this machine!

K 750
SpeedMill

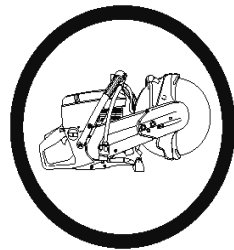

TABLE OF CONTENTS

Section	Page No.	Section	Page No.
Table of Contents.....	2	Tools.....	7
Contact Information.....	2	Assembly.....	7 - 8
Symbols.....	3	Operation.....	8 - 9
Introduction.....	4	Maintenance.....	10
Safety Instructions.....	4 - 5	Spare Parts.....	10 - 11
What-Is-What (Part Identification).....	6	Pipe Application Chart.....	12
Uses.....	7	Operator Tips.....	13

CONTACT INFORMATION

Husqvarna Construction Products, North America

Corporate Office
17400 West 119th Street, Olathe, Kansas 66061 USA
Corporate Office Phone: 913-928-1000
Corporate Office Fax: 913-438-7951
www.husqvarnacp.com

For local service, please contact your local Husqvarna Construction Products representative.
Para efectuar un servicio local, póngase en contacto con su representante local de
Husqvarna Construction Products.

Pour toute réparation, contacter le représentant local de Husqvarna Construction Products.
Für Service vor Ort wenden Sie sich bitte an Ihren örtlichen Vertreter von
Husqvarna Construction Products.

Neem voor plaatselijke service contact op met uw plaatselijke vertegenwoordiger van de constructie-
producten van Husqvarna.

Per assistenza, rivolgersi al rappresentante di zona della Husqvarna Construction Products.
För service på platsen, kontakta din lokala representant för Husqvarna Construction Products.
Para obter serviço técnico local, contactar o representante da Husqvarna Construction Products

Husqvarna Construction Products, North America
17400 West 119th Street, Olathe, Kansas 66061 USA
Toll-Free Telephone: 800-288-5040, Telephone: 913-928-1300, Fax: 913-438-7938

SAFETY SYMBOLS & DECALS

Key to symbols

WARNING! The machine can be a dangerous tool if used incorrectly or carelessly, which can cause serious or fatal injury to the operator or others.



Operator must wear head protection such as a hard hat!



Please read the operator's manual carefully and make sure you understand the instructions before using the machine.



Operator must wear protective footwear such as safety shoes or safety boots!



WARNING! Dust forms when cutting, this can cause injuries if inhaled. Use an approved breathing mask. Avoid inhaling petrol fumes and exhaust fumes. Always provide for good ventilation.



The operator must wear protective clothing appropriate to the work he is doing. Never wear loose clothing or jewelry. Keep long hair tied back. Keep your hair, clothing, and gloves away from the rotating tool!



The working area must be completely clear, well lit and all safety hazards removed.



WARNING! Sparks from the cutting blade can cause fire in combustible materials such as: petrol (gas), wood, dry grass etc.



Any persons not involved in the work, should leave the area.



Operator must wear eye protection!



Operator must wear hearing protection!



Operator must wear respiratory protection!
(Reference OSHA 29CFR 1910.95, 1910.133-138)



FOR INFORMATION ON DECALS FOR THE SPEEDMILL, SEE THE SPARE PARTS LIST SECTION OF THIS DOCUMENT.

FOR INFORMATION ON DECALS FOR THE K750 POWER CUTTER, SEE THE SPARE PARTS LIST FOR THE K750.

SAFETY INSTRUCTIONS

Introduction

Thank you for purchasing your new machine from Husqvarna Construction Products. We have provided important safety messages in this manual and on the machine. Please read these messages carefully. A safety message alerts you to potential hazards that could hurt you or others. Each safety message is preceded by a symbol or the safety alert symbol (⚠) and one of two words, **WARNING**, or **CAUTION**.

These signal words mean:

WARNING: Indicates a hazardous situation which, if not avoided, COULD result in death or serious injury.

CAUTION: Indicates a hazardous situation which, if not avoided, COULD result in minor or moderate injury. It may also be used to alert against unsafe practices.

Each message tells you what the hazard is, what can happen, and what you can do to avoid or reduce injury.

NOTICE: Indicates a hazardous situation which, if not avoided, COULD result in property damage. Your machine or other property can be damaged if you don't follow this instruction.

If the label is worn, damaged, or is illegible, it should be replaced.

Contents of Package



Verify the contents of the package:

- SpeedMill Power Cutter.
- Hub and 2.00" Nut.
- Document Package. Operation Manual for Power Cutter, Spare Parts List for Power Cutter, Operation Manual / Spare Parts List for Speed Mill Accessory (This Document).

If these items are not included in the package, contact our customer service department at the telephone number shown in this document.



Safety Instructions:

 WARNING!	
 	<p>Before starting up machine make sure you completely read these instructions and the power cutter operation manual. Be familiar with the functions of the machine before operation!</p> <p>Your SpeedMill comes with two Operator's Manuals. One for the SpeedMill attachment and one for the K750 power head. It is the owner's responsibility to ensure that all operators of this SpeedMill have read and understood the content of both manuals before using the products.</p>

Common sense:

The focus of this manual is HOW to operate and service the equipment safely. It is not possible to cover every conceivable situation you can face when using this equipment. Therefore use this product only in a manner described in this manual. Operation or handling the machine in any other manner can lead to serious injury or death. If a situation is not described in this manual it should be considered dangerous and not be done.

If you are unfamiliar with this product make sure that you carefully understand how it functions and practice all operations and handling before putting the machine to use. Familiarize yourself in the presence of an experienced operator. Avoid all situations that are beyond your capability.

If you feel uncertain about operating procedures after reading these instructions DO NOT operate the machine until you have consulted an experienced operator.

If you have further questions you can contact the closest Husqvarna Construction Products location by writing or calling, see information below. You can also find the closest location by searching the internet at: www.husqvarnacp.com. Husqvarna Construction Products will willingly be of service and provide you with advice as well as help you to use your product both efficiently and safely. Additional manuals are available at NO CHARGE and can also be obtained on the internet site.

Husqvarna Construction Products
17400 West 119th Street
Olathe, Kansas 66061
USA

Toll Free no: 800 288 5040 (USA & CANADA)
Phone no: 913 928 1000
Fax no: 913 438 7951

Internet Site: www.husqvarnacp.com

SAFETY INSTRUCTIONS

WARNING!

Read, understand, and follow all warnings and instructions both manuals. Failure to do so may result in serious personal injury as well as damage to the equipment. It is not possible to cover all potential risk situations that can arise from pipe cutting and beveling within these instructions. Therefore use common sense and caution at all times.

Remember: "If you don't know – don't do."

The SpeedMill may not be modified from its original design without the manufacturer's approval in writing. Unapproved modifications can result in serious injury.

All operators must be trained in the proper use of this machine. It is the owner's responsibility to explain the content of this manual to all operators and ensure that they receive the necessary training to safely operate this machine.

PERSONAL SAFETY

Stay alert, watch what you are doing, and use common sense when operating this SpeedMill or any other power tool. Do not use when tired or under the influence of drugs, alcohol, medication, or any substance that could affect your judgment. A moment of inattention during operation may result in serious personal injury.

Keep proper footing and balance at all times. Do not overreach or operate from a ladder. Do not operate above chest height. If necessary use proper scaffolding to reach a safe operating height.

Use personal safety equipment. Always wear eye protection, hard hat, hearing protection, non-slip safety shoes and gloves. Respirator mask must be used when dry-cutting. (Reference OSHA 29CFR 1910.95, 1910.133-138)

Dress properly. Never wear loose clothing or jewelry. Keep long hair tied back. Keep your hair, clothing, and gloves away from the rotating blade.

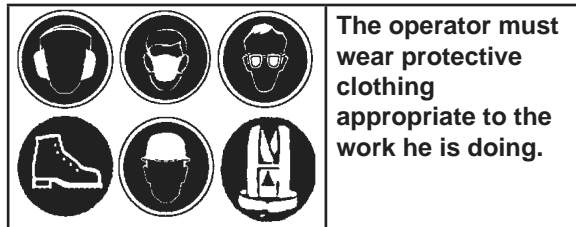

Do not use the SpeedMill if the ON/OFF switch does not turn it on or off. Have the switch replaced before the SpeedMill is used again.

WORK AREA SAFETY

Keep the work area organized. Maintain a firm grip of the SpeedMill and have a proper footing and balance at all times.



Do not operate your SpeedMill in an explosive atmosphere. Sparks may ignite flammable liquids, gases, or dust. This is a concern when old pipes are being repaired.

Keep all bystanders at a safe distance. Bystanders can be a distraction that can cause you to lose control.

CHOICE OF BLADE

Use only 12" high speed abrasive concrete cutting blades for cutting specified PVC pipe with the SpeedMill.

Use only blades designated **High Speed** blade with a minimum speed rating of 6300 rpm. Many blades are not made for hand held high speed saws and have a lower speed rating (marked on label). Such blades might brake at higher speeds with possible severe injury as a result.

Diamond blades shall not be used while cutting any plastic pipe due to the increased risk of "kick-back". (Regarding kick-back see K750 operation manual).

Use of carbide tipped blades or any blade with cutting teeth, is a violation of OSHA regulations and shall never be used.

WHAT IS WHAT

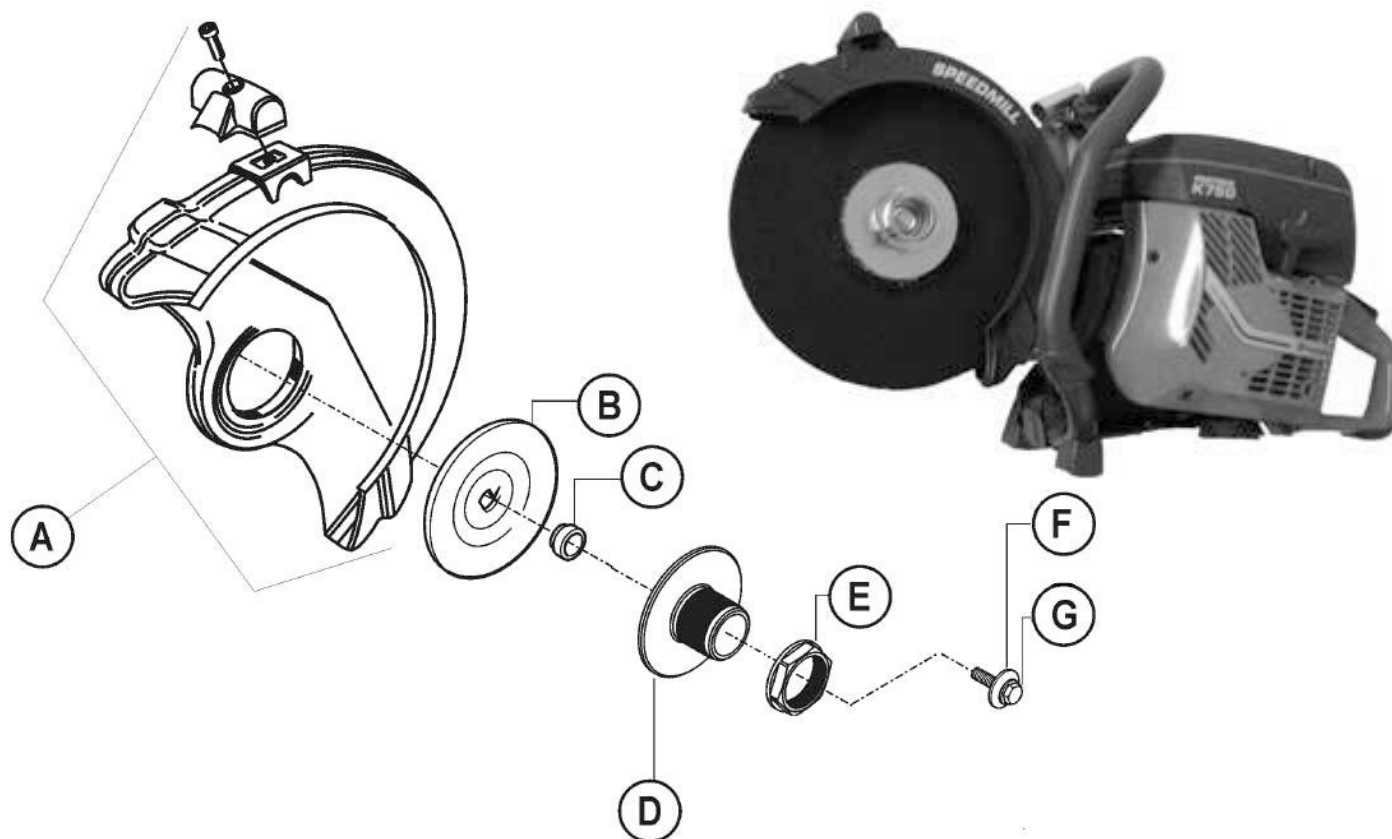

WHAT IS WHAT (PARTS IDENTIFICATION)

A. SpeedMill BLADE GUARD: Designed specifically for the SpeedMill. One side is open to allow mounting of the SpeedMill Bowls. Read this Operation Manual for more information. See SpeedMill Spare Parts List in this document for part number.

B. Inner Flange: Used to support Abrasive Blade. See K750 power cutter Operation Manual for additional instructions on this item.

C. Blade Arbor Spacer: Used to support Abrasive Blade. See K750 power cutter Operation Manual for additional instructions on this item.

D. SpeedMill Hub: Designed specifically for the SpeedMill. Acts as an outer flange for the Abrasive Blade, and a mounting arbor for the SpeedMill Bowls (E, F, G). Read this Operation Manual for more information. See SpeedMill Spare Parts List in this document for part number.

E. SpeedMill Hub Nut: Designed specifically for the SpeedMill. Holds SpeedMill accessories in position. Read this Operation Manual for more information. See SpeedMill Spare Parts List in this document for part number.

F. Arbor Bolt Washer: Used to hold SpeedMill Hub (D) in position. See K750 power cutter Operation Manual for additional instructions on this item.

G. Arbor Bolt: Used to hold SpeedMill Hub (D) in position. See K750 power cutter Operation Manual for additional instructions on this item.

Note: See K750 Power Cutter Operation Manual, and K750 Spare Parts List for information on any other parts of this machine. High Speed Abrasive Blade Not Included.

USES, TOOLS, AND ASSEMBLY

Uses: Cutting and beveling of waste/sewer and supply water PVC pipe with the proper beveling accessory. Note this machine is not for cutting and beveling of any non-plastic material. Follow chart for correct accessory to pipe being cut and beveled (See pipe application chart included in document package).



WARNING!

ONLY CUT or BEVEL PVC Plastic Pipe with a machine equipped with a SpeedMill accessory!

DO NOT cut other materials with this machine!

DO NOT cut or bevel ductile iron pipe with a machine equipped with a SpeedMill accessory!

DO NOT use machine as a standard power cutter without proper power cutter blade guard. Refer to page 10 "converting the Speedmill to a regular power cutter"

Tools: 12" (305mm) diameter abrasive blade, with a 1" (25.4mm) arbor (not included).



WARNING!

Use ONLY High Speed Reinforced Abrasive Blades with a minimum speed rating of 6300 rpm.

DO NOT use carbide tipped, wood cutting, or circular saw blades with this machine!

First Time Assembly:

Tools Required:

- Screwdriver (for arbor lock)(not included).
- 2" (50.8mm) socket, and socket wrench (not included).
- Combination spanner (supplied with machine).
- Torque wrench.



Loosen and remove the blade shaft screw & washer from the power cutter. Use the combination spanner supplied, and a Screwdriver to lock the blade shaft in position, if required.



Use a Screwdriver to lock the blade shaft in position. Push the screwdriver into the slot (see picture) and rotate the arbor until the screwdriver stops the rotation.

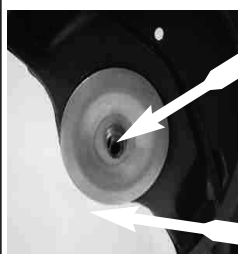

Verify that 1" (25.4mm) adapter (P/N 506 37 96-25) is pushed onto blade shaft so it contacts the inner flange. The mounting surfaces of the flange and bushing arbor must be undamaged, clean, and free of debris. Verify that the flange (P/N 506 02 87-01) has a diameter of 4.13" (105mm).



Mount a 12" (305mm) diameter, 1" (25.4mm) arbor High Speed Reinforced Abrasive Blade (not included) on the blade shaft.



Mount the SpeedMill accessory hub. Align the slot in the SpeedMill accessory hub with the face of the shaft. Make sure the flange face of the SpeedMill accessory hub contacts the face of the blade.



Install the blade shaft bolt into the hub assembly.



Using combination spanner, supplied with the machine, tighten blade shaft bolt by turning it clockwise. Torque to 130-215 in-lbs. (15-25 Nm).

Select the SpeedMill accessory for the type of PVC pipe to be bevelled using the Pipe Application Chart included on page 12 of this manual.

Bowl Bevelers 506 11 97-01 for:

Waste/Sewer/Drain 4" to 8" in diameter.

Ring Beveler 506 11 96-01 for:

Waste/Sewer/Drain 10" to 36" in diameter.

Supply/Water 4" to 24" in diameter.

ASSEMBLY AND OPERATION



Assembling the beveling bowls to the SpeedMill.
Bowl Bevelers 506 11 97-01 for:
 Waste/Sewer/Drain 4" to 8" in diameter.

⚠ CAUTION!

Always install the 8" SpeedMill Bowl (P/N 542 19 61-89) before using the machine! The 8" SpeedMill Bowl must always be installed even if the machine will only be used to cut and bevel smaller diameter pipes. Besides serving as a beveler for 8" pipes, the 8" flange is also designed to cover the area between the guard and the flange and to prevent unintentional contact with the blade.



Mount the beveling bowl in order 8" first, 6" second, and 4" last.

ALWAYS mount the 8" bowl, it is designed to shield operator in case the blade breaks.



Install and tighten the 2" (50.8mm) hub nut with the proper tool. Torque to 130-215 in-lbs. (15-25 Nm).
 NOTE: Do not tighten excessively – nut will tighten during cutting process – making disassembly difficult.



When tightening the hub nut, use a screwdriver to lock the blade shaft in position. Push the screwdriver into the slot (see picture) and rotate the arbor until the screwdriver stops the rotation. Do not use slots in beveling bowl to hold, may damage bowls.



Before using the assembled machine, completely read the power cutter operation manual supplied with this machine.

Assembling the beveling ring to the SpeedMill.



Ring Beveler 506 11 96-01 for:
 Sewer/Drain 10" to 36" in diameter.
 Supply/Water 4" to 24" in diameter.



Mount the Ring Beveler assembly onto the hub shaft.



Install and tighten the 2" (50.8mm) hub nut with the proper tool. Torque to 130-215 in-lbs. (15-25 Nm).
 NOTE: Do not tighten excessively – nut will tighten during cutting process – making disassembly difficult.



When tightening the hub nut, use a screwdriver to lock the blade shaft in position. Push the screwdriver into the slot (see picture) and rotate the arbor until the screwdriver stops the rotation.



Before using the assembled machine, completely read the power cutter operation manual supplied with this machine.

OPERATION:

⚠ CAUTION!



Before starting machine, make sure you completely read these instructions and the power cutter operation manual. Be familiar with the functions of the machine before operation!

OPERATION

WARNING!

EVACUATE PIPE CONTENTS before cutting or else an **EXPLOSION** may occur! Static electricity from cutting operation may cause gas or other pipe contents to explode.

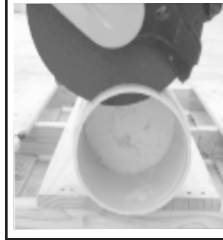

Rotate pipe and repeat this cutting process until pipe circumference is cut.



Position plastic pipe so pipe end is off the ground. Secure pipe in place if required. Example: Set plastic pipe between two boards of a wooden pallet.



Bevel Pipe:
Position SpeedMill Bowl near end of pipe to be beveled. Accelerate power cutter to full throttle.

WARNING!

Before starting machine, verify that when SpeedMill Bowl and blade are positioned to cut / bevel the plastic pipe, that the cutting area is cleared of all objects.



Align proper SpeedMill Bowl with end of pipe, and move toward the pipe so that the pipe is slightly beveled.
Note: The bevel required is usually quite small, so do not remove excessive pipe material.



Start machine per instructions in K750 Power Cutter Operation Manual.

WARNING!

HOLD MACHINE ONLY at front and rear handles!

NEVER bevel or cut material while holding the pipe with your hands!

DO NOT use blade guard pivot handle as a hand hold while operating machine!

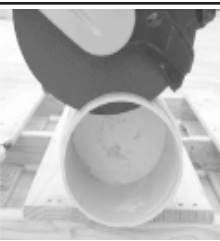

Position machine at top of plastic pipe to begin cutting through the pipe wall.

NOTE:
When using the ring beveler, the pipe is cut and beveled in one operation.

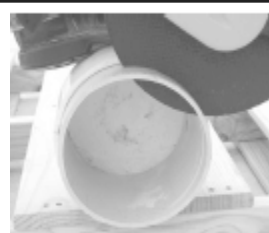

Move saw forward while maintaining a "square cut" on the end of the pipe. This means the cut should always be perpendicular to the length of the pipe.

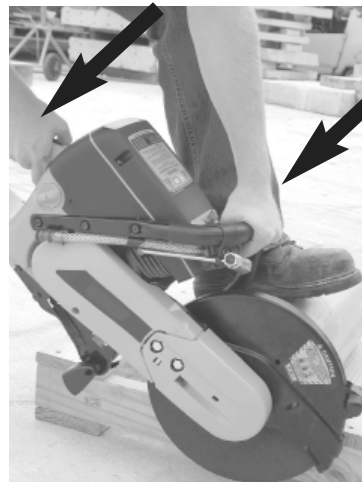

HOLD MACHINE ONLY at front and rear handles, as shown in the photo to the left.

MAINTENANCE

MAINTENANCE:

CAUTION!

Allow SpeedMill Bowls to cool before performing any maintenance.

NOTICE!

DO NOT hold SpeedMill Bowls using a screwdriver or other device through the slots in the bowl. Damage to the bowls or abrasive coating could occur.

DO NOT use a screw driver or similar in the slots of the SpeedMill Bowls to lock the blade. If you do it is likely the flanges will be damaged and become unusable.

Use the proper procedure to lock the blade when attaching or removing the blade or flanges – See below, or see K750 Operation Manual.

CONVERTING THE SPEEDMILL TO A REGULAR POWER CUTTER.

The guard on the SpeedMill is designed to work together with the special outer flange and SpeedMill Bowls used on the SpeedMill. The 8" (200mm) SpeedMill Bowl must always be installed when the SpeedMill is used and the SpeedMill shall not be used for any other purpose than those mentioned in "USES" section (p7) of this document. Should you desire to convert the SpeedMill to a regular power cutter you must replace the cutting head with an original 12" or 14" cutting head attachment. We recommend you have an authorized dealer do the conversion.

WARNING!

NEVER use the SpeedMill as a regular power cutter!

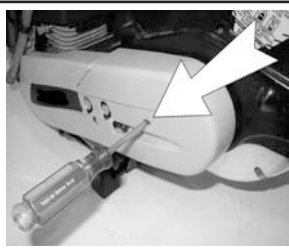

When removing the Hub nut, use a Screwdriver to lock the blade shaft in position. Push the screwdriver into the slot (see picture) and rotate the arbor until the screwdriver stops the rotation.

Inspect the SpeedMill Bowls

Always inspect the SpeedMill Bowls before you start cutting. Small nicks or scratches can be sanded smooth. If the SpeedMill Bowl has been bent or distorted in any way it must be replaced.

Cleaning



Plastic debris from a smaller flange often lodges itself in the bigger flange during cutting. This can easily be removed once the flanges have cooled down.

Use compressed air to blow shavings from SpeedMill Bowl. DO NOT scrape shavings from bowl using a screwdriver or any other hard metallic tool. Damage to the bowls or abrasive coating could occur.

SPARE PARTS:

The parts required for the SpeedMill Accessory are shown on the next page. For any other parts used on this machine see the power cutter spare parts list (included).

SPARE PARTS

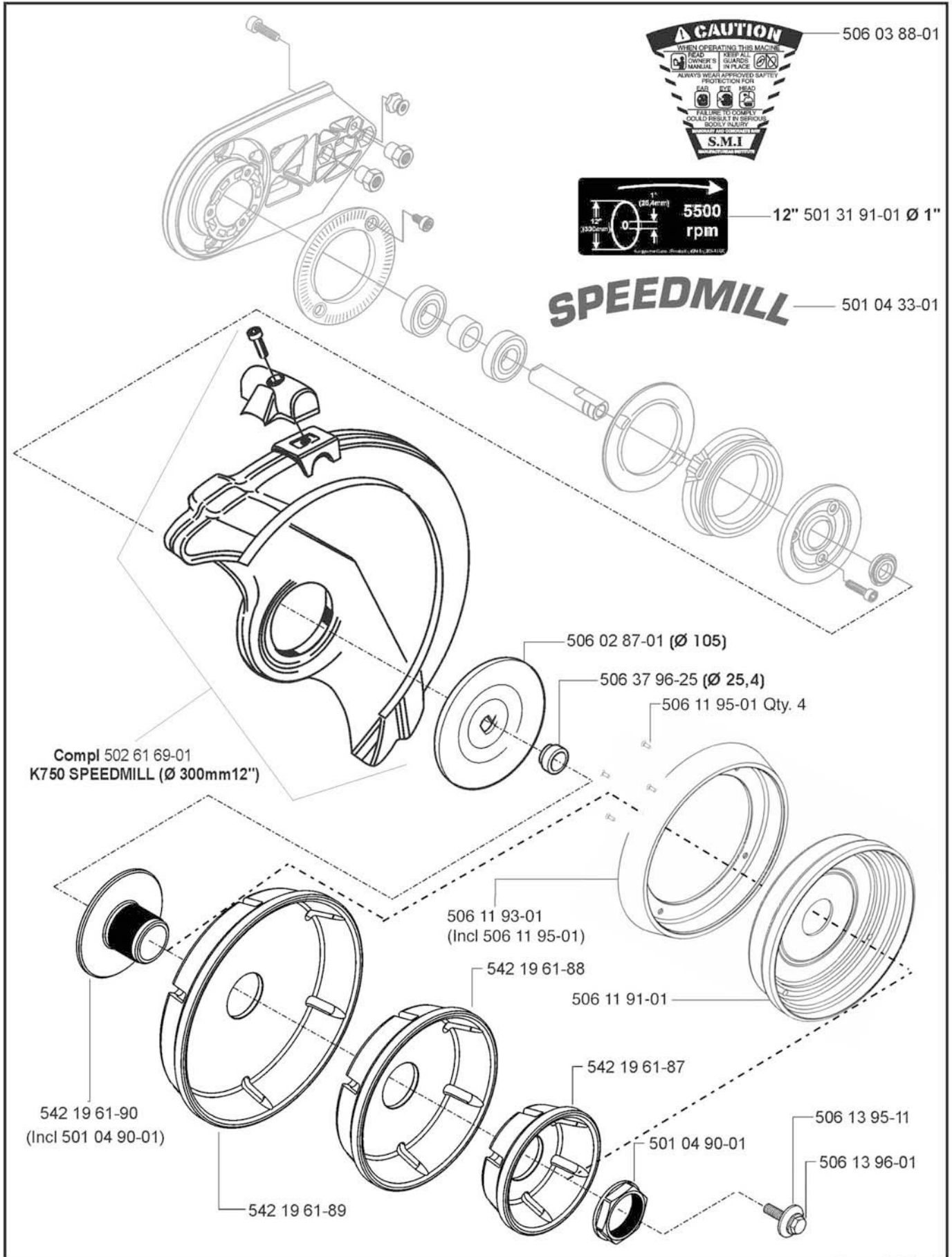

Pipe Application Chart

Husqvarna Speedmill II - Bowl & Ring Bevelers Application Chart

Classes of Pipe

Sizes	PSM		CIOD		IPS ASTM D2241			
	SDR 35	SDR 26	C900	C900/905	SDR 26	SDR 21		
4"	506119701 Bowl Bevelers				NA			
6"					506119601 Ring Beveller		506119601 Ring Beveller	
8"								
10"								
12"								
14"								
15"								
16"	506119601 Ring Beveller							
18"								
21"								
24"	NA		NA					
27"								
36"								



Husqvarna Speedmill Operators Tip Sheet

1. *Bowl abrasive cleaning* - The bowls will gather PVC dust usually in the outer bowl which is not being used. For instance if the 4" bowl is used a lot, the 6" bowl will accumulate dust on the abrasive. If a bowl with dust buildup on it is applied to the cut end of the pipe, it will usually self clean itself. However, if a bowl has excessive dust buildup, a large nylon bristled toothbrush can be used.
2. *Pipe platform/elevator* - Raising the pipe off the ground or stabilizing it is necessary for the "bowl beveling". Beveling pipe with a "ring beveller" can be done on a platform or the ground, whichever is preferred by the operator.
3. *Short pipe beveling* - When beveling a short piece of pipe for a connection, remember to secure the pipe before beveling.
4. *Optimal saw RPM* - For the "bowl bevellers", optimal and consistent use of RPM's of the saw is vital to efficiency. Before the bowl is applied to the cut end, apply saw at full power.
5. *Bowl and Ring beveller application* - While keeping the saw true on a vertical plane, apply lateral and even pressure towards the section of pipe.
Some pipe classes may require a '4 point pressure' application of the bowl, after the first initial even pressure of the bowl. Simply work around the pipe with the bowl at 4 equidistant points of pressure, in succession.
For Ring Beveller, as you cut and bevel at the same time, simply keep the saw RPM's consistently at full power as you work through the pipe.
6. *Straight cut self correction* - When cutting a piece of sewer pipe, the user may accidentally end the cut unevenly. In most cases, the bowl will automatically reduce the notch at the uneven intersection. Simply apply more pressure at that point of the pipe, if necessary. Or bevel normally, and inspect the first bevel, and reapply the bowl at the uneven point. If the notch isn't too big, the bowl will correct it.
The Ring Beveller makes cutting the pipe straight easier than ever before. When the abrasive area on the ring is engaged on the pipe, the abrasive blade on the saw will be more stable as opposed to a regular power cutter. First time pipe cutters can usually cut pipe straight within a few minutes of practice.

Always read your Owner's Manual for safety and proper operation.



www.husqvarnacp.com

525 24 82-01