

Operator's manual **K950 Chain**



**Read these instructions carefully and make sure you understand them
before using the machine.**

English

SYMBOL EXPLANATION

Symbols on the cut-off saw:



WARNING! The cut-off saw can be dangerous! Careless and incorrect use can result in serious or fatal injury to the operator or others.



Please read the instructions carefully and make sure you understand them before using the cut-off saw.



Always wear:

- Approved protective helmet
- Approved hearing protection
- Protective glasses or visor



This product is in accordance with applicable CE directives.



Warning

Cutting creates a lots of dust which can cause inhalation damages. Use appropriate dust mask or respirator protection. Avoid breathing petrol fumes and exhaust gases. Provide for good ventilation.



Warning

Sparks from the cut-off saw can cause fire in combustible materials such as: petrol (gas), wood, dry grass etc.



Noise emission to the environment according to the European Community's Directive. The machine's emission is specified in chapter Technical data and on label.

Symbols in the Operator's Manual:

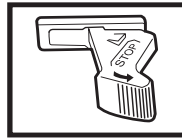

Switch off the engine by moving the stop switch to the STOP position before carrying out any checks or maintenance.

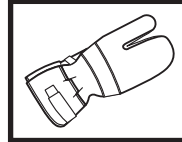

Always wear approved protective gloves.

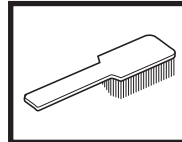

Regular cleaning is required.

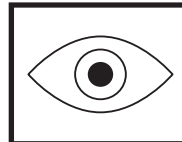

Visual check.



Protective glasses or a visor must be worn.



Run position.

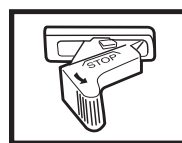

Stop with spring loaded return to Run position.

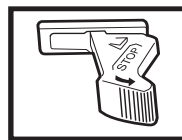

Stop, in fixed position.

CONTENTS

Before using your new cut-off saw:

- Read the Operator's Manual carefully.
- Check the assembly and adjustment of the cutting chain, see chapter "Assembly".
- Start the engine and check the carburetor settings. See chapter "Maintenance", section "Carburetor". When adjusted correctly the cutting chain should not rotate when idling. Setting the idling speed is described in the Operator's Manual. Adjust the speed according to these instructions. Do not use the cut-off saw if the idling speed is not correctly adjusted!
- Let your Husqvarna dealer check the cut-off saw and carry out essential adjustments and repairs.



WARNING!
Under no circumstances should you modify the original design of the cut-off saw without approval from the manufacturer. Always use genuine spare parts. Unauthorized modifications or accessories may lead to serious injury or death.

Your warranty does not cover damage or liability caused by the use of non-authorized accessories or replacement parts.



WARNING!
Use of products which cut, grind, drill, sand or shape material can generate dust and vapors which may contain harmful chemicals. Know the nature of the material being worked on and wear appropriate dust mask or respirator protection.



WARNING! The ignition system of this machine produces an electromagnetic field during operation. This field may under some circumstances interfere with pacemakers. To reduce the risk of serious or fatal injury, we recommend persons with pacemakers to consult their physician and the pacemaker manufacturer before operating this machine.

Husqvarna Construction Products has a policy of continuous product development. Husqvarna reserves the right to modify the design and appearance of products without prior notice and without further obligation introduce design modifications.

All information and all data in the Operator's Manual were applicable at the time the Operator's Manual was sent to print.

List of Contents

Symbol explanation	2
Safety instructions	
Personal protective equipment	4
The machine's safety equipment	4
Control, maintenance and service of the machine's safety equipment	4
General safety instructions	6
Storage	6
Fuel safety	7
General working instructions	7
Using	8
Cutting	8
Kickback	10
Care and storage	10
Cutting equipment	11
Cutting chains	11
What is what?	
What is what on the machine?	12
Assembly	
How to tension the chain	13
How to change the chain and rim	13
How to change the clamping force of the bar	14
Fuel handling	
Fuel mixture	15
Fuelling	15
Start and stop	
Start and stop	16
Maintenance	
Carburetor	17
Fuel filter	18
Air filter	18
Starter	19
Ignition system	20
Spark plug	20
Cooling system	20
Muffler	20
Daily maintenance	21
Weekly maintenance	21
Monthly maintenance	21
Technical Data	
K950 Chain	22

SAFETY INSTRUCTIONS



WARNING! Incorrect or careless use of a cut-off saw can turn it into a dangerous tool that can cause serious or even fatal injury. It is extremely important that you read and understand this manual.

PERSONAL PROTECTIVE EQUIPMENT



WARNING! When using a cut-off saw, approved protective equipment must be used. Personal protective equipment does not eliminate the risk of accidents, however, it can reduce the effects of an injury in the event of an accident. Ask your dealer for help when choosing protective equipment.

- PROTECTIVE HELMET
- EAR PROTECTION
- PROTECTIVE GLASSES OR FULL FACE PROTECTION

- BREATHING MASK

- HEAVY-DUTY, FIRM GRIP PROTECTIVE GLOVES

- SNUG-FITTING, HEAVY-DUTY, COMFORTABLE CLOTHING THAT ALLOWS FULL FREEDOM OF MOVEMENT
- LEG PROTECTION (TO PROTECT AGAINST SPARKS AND CUTTING FRAGMENTS)

- ANTI-SLIP BOOTS WITH STEEL TOE CAPS

- FIRST AID KIT SHOULD ALWAYS BE ON HAND

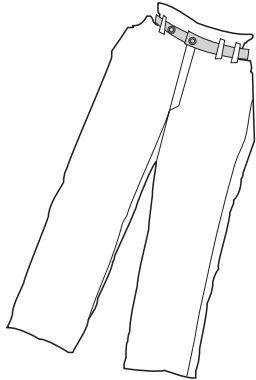
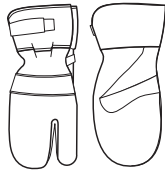
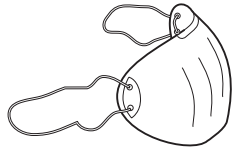
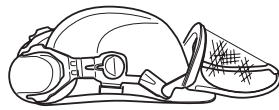

THE MACHINE'S SAFETY EQUIPMENT

This section describes the cut-off saw's safety equipment, its function and how checks and maintenance are carried out to ensure that it operates correctly.



WARNING! Never use a cut-off saw with defective safety equipment. Follow the control, maintenance and service instructions described in this manual.

1 Anti-vibration system

Your cut-off saw is equipped with an anti-vibration system. This is designed to give as low vibration levels and comfortable usage as possible.

The cut-off saw's antivibration system reduces the transfer of vibration between the engine/cutting equipment and the operator. The engine body including the cutting equipment is suspended in a handle system via anti-vibration elements.

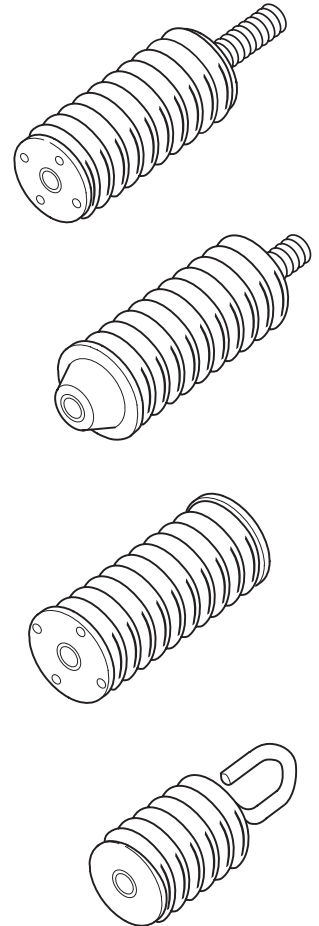

2 Stop switch

The stop switch should be used to stop the engine.

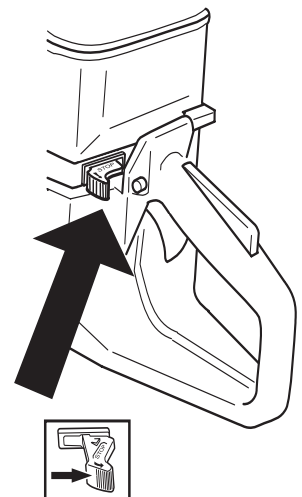

SAFETY INSTRUCTIONS

3 Muffler



WARNING! During use and for some time after the muffler is very hot. Do not touch the muffler if it is hot!

The muffler is designed to give the lowest possible noise level and to direct the engine's exhaust fumes away from the user. The engine's exhaust fumes are hot and can contain sparks, which can lead to the outbreak of fire.

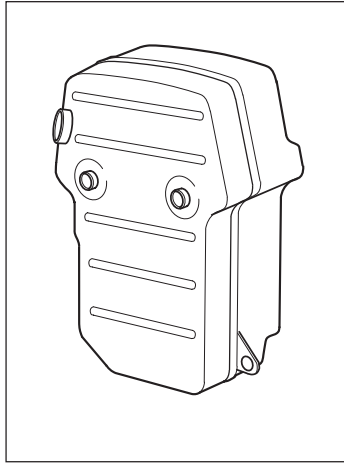

IMPORTANT INFORMATION! It is extremely important that the instructions for checking, maintaining and servicing the muffler are followed. (see the section "Control, maintenance and service of the machine's safety equipment").



WARNING! The inside of muffler contain chemicals that may be carcinogenic. Avoid contact with these elements in the event of a damaged muffler.

4 Throttle lock

The throttle lock is designed to prevent accidental operation of the throttle control. When you press the lock (A) (i.e. when you grasp the handle) it releases the throttle trigger (B). When you release the handle the throttle lock both move back to their original positions. This movement is controlled by two independent return springs. This arrangement means that the throttle control is automatically locked at the idle setting when you release the handle.

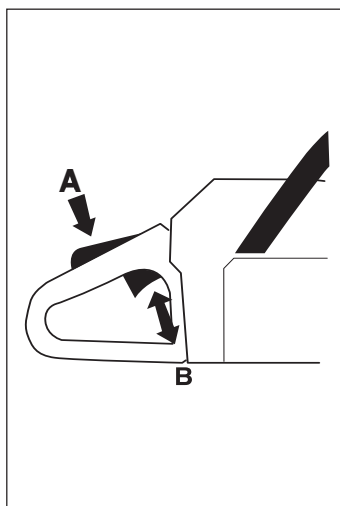

Control, maintenance and service of the machine's safety equipment



WARNING! All service and repairs to the cut-off saw require special training. This applies especially to the cut-off saw's safety equipment. If the cut-off saw does not meet any of the controls listed below you should contact your service workshop. The purchase of one of our products guarantees that professional repair and servicing will be carried out on it. If the point of purchase is not one of our servicing dealers, please ask for details of the closest service workshop.

1 Anti-vibration system

Check the anti-vibration elements regularly for material cracks and deformation.

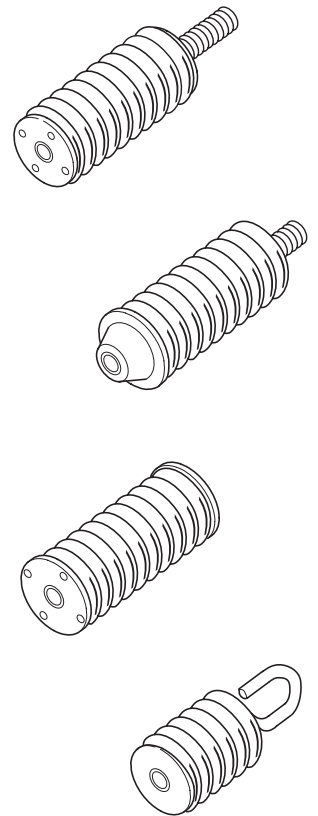

Check that the anti-vibration elements are securely mounted between the engine unit and the handle system.

2 Stop switch

Start the engine and make sure that the engine stops when the stop switch is moved to the stop position.

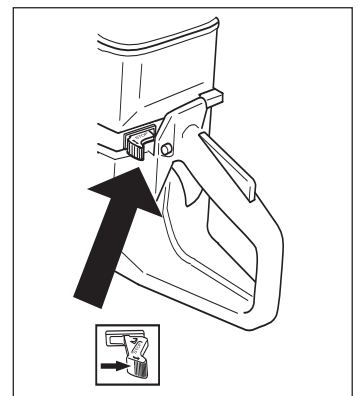

SAFETY INSTRUCTIONS

3 Muffler

Never use a machine that has a defective muffler.

Check regularly that the muffler is secured to the engine body.

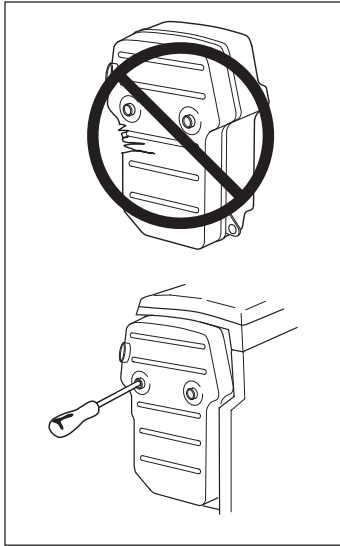

4 Throttle lock

1 Make sure the throttle control is locked at the idle setting when you release the throttle lock.

2 Press the throttle lock and make sure it returns to its original position when you release it.

3 Check that the throttle control and throttle lock move freely and that the return springs work properly.

4 Start the saw and apply full throttle. Release the throttle control and check that the chain stops and remains stationary. If the chain rotates when the throttle is on idle setting you should check the carburettor idle adjustment. See the section on "Maintenance".

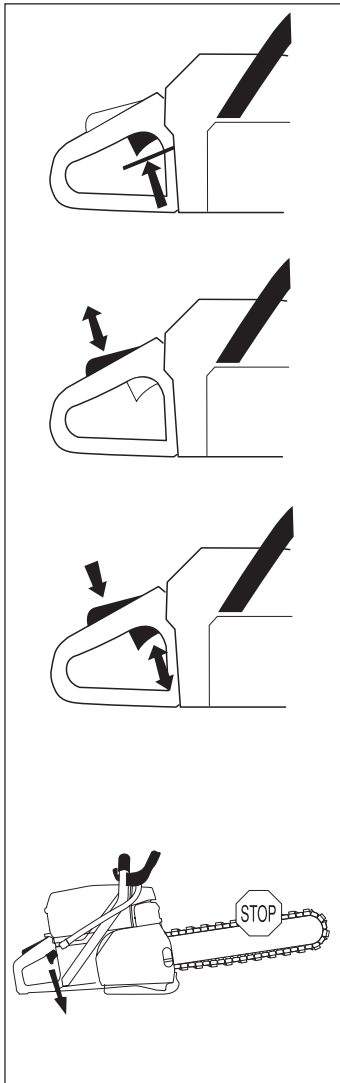

GENERAL SAFETY INSTRUCTIONS

IMPORTANT INFORMATION!

Do not use the cut-off saw until you have read the entire contents of this Operator's Manual. All servicing, in addition to the points listed in the section "Control, maintenance and service of the machine's safety equipment", should be carried out by trained service specialists.

- Use the equipment recommended in the chapter "Personal protective equipment".
- Never use the machine when you are tired, under the influence of medicines/drugs or alcohol.
- Do not lend the cut-off saw to anyone without providing this Operator's Manual. Ensure the person using the cut-off saw understands the information in this Operator's Manual.

Storage

- Store the cut-off saw under lock and key so that it's out of reach for children and unauthorised persons.



WARNING! Never use a cut-off saw with defective safety equipment. The cut-off saw's safety equipment should be checked and maintained as described in this Operator's Manual. If your cut-off saw does not meet any of these controls you should contact your service workshop.

SAFETY INSTRUCTIONS

Fuel safety

(Filling/Fuel mixture/Storage)



WARNING! Exercise great care when handling fuel. Bear in mind the risk of fire, explosions and inhaling fumes.

- Never fill the machine while the engine is running.
- Provide good ventilation when filling or mixing fuel (gasoline and 2-stroke oil).
- Move the machine at least 3 m from the filling position before starting.
- Never start the machine:
 - a) If you have spilt fuel on it. Wipe up all spillage.
 - b) If you have spilt fuel on yourself or your clothes. Change your clothes.
 - c) If there is a fuel leak. Make regular checks for leakage from the fuel cap and the fuel supply pipes.
- Store the cut-off saw and fuel so that any leakage or fumes do not risk coming into contact with sparks or naked flames. For example, electric machines, electric motors, electrical switches/power switches, heaters or the like.
- When storing fuel, approved containers intended for this purpose must be used.
- When storing the cut-off saw for long periods the fuel tank must be emptied. Contact your local fuel station to find out how to dispose of excess fuel.
- Use a Husqvarna fuel can with an anti-spill device.

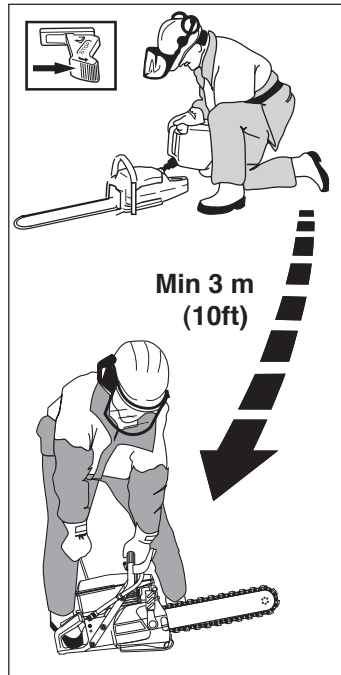

WARNING! Use a Husqvarna fuel can with an anti-spill device. Fuel and fuel fumes are highly flammable. Think of the risks of fire, explosion and breathing in fumes. Stop the engine before refuelling. Do not overfill with fuel. Mop up any spills on the ground or the machine. If you spill fuel on yourself or your clothes, change your clothes. Move the machine at least 3 metres from the refuelling site before starting.

GENERAL WORKING INSTRUCTIONS

This section takes up the basic safety precautions for working with the cut-off saw. Follow these general working instructions, but never use a machine without the possibility of calling for help in the event of an accident.

Basic safety precautions

IMPORTANT INFORMATION! Never work with a cut-off saw that is defective or incorrectly adjusted. Do not work with a cut-off saw that is incomplete or where assembly has not been carried out in a satisfactory manner. Check that the cutting chain stops rotating when the throttle is released. If you encounter a situation where you are uncertain how to proceed you should ask an expert. Avoid all usage which you consider to be beyond your capability.

- Check that no one is in the immediate vicinity when the machine is started or while working with the machine to ensure that people, animals or other things cannot affect your control of the cut-off saw.
- Avoid usage in unfavourable weather conditions, for example, thick fog, heavy rain, strong winds or extreme cold, etc. To work in bad weather conditions is tiring and can create dangerous circumstances, e.g. slippery surfaces.
- Never start to work with the cut-off saw before the working area is clear and you have a firm foothold. Look out for any obstacles with unexpected movement. Ensure when cutting that no material can become loose and fall, causing operating injury. Take great care when working on sloping ground.
- Make sure clothing and parts of the body do not come into contact with the cutting chain when the engine is started.
- Maintain a safe distance from the cutting chain when the engine is running.
- Ensure that the working area is sufficiently illuminated to create a safe working environment.
- Check the cutting area for buried cables and wires.
- Consider the carbon monoxide risk! The diamond chain saw emits highly dangerous carbon monoxide and as a result must never be used in unventilated areas. Even used in deep recesses it represents a risk if badly ventilated. Carbon monoxide is heavier than air and collects at the bottom of recesses.



Only use the machine in areas with good ventilation. Neglect can result in serious injury or death.

SAFETY INSTRUCTIONS

Using



WARNING!
Never start the saw without the complete bar and chain fitted.

Wet cutting

The diamond chain saw must always be run with water cooling. Dry cutting causes immediate overheating and bar and chain failure with a risk of personal injury. In addition to cooling the bar and chain, the flow of water pushes particles away from the bar and the drive links. As a result it is important with a high water pressure. The water pressure should be at least 2.5 bar and a maximum of 11 bar. The recommended pressure is approx. 5 bar.

Working speed

Under normal conditions the machine should run at full throttle. The feed pressure is adjusted so that the speed drops to approx. 20–30 % under maximum speed; this gives the best cutting efficiency and economy.

Cutting



WARNING! A safe distance from the cut-off saw is 15 metres. You are responsible that animals and onlookers are not in the working area. Do not start to work with the cut-off saw before the working area is clear and you have a firm foothold.

- Start cutting with the engine at full throttle.
- Always hold the cut-off saw firmly, with both hands. Hold the machine so that the thumb and fingers grip around the handle.



Over exposure to vibrations can result in blood-vessel or nerve injury to persons suffering with blood circulation problems. Seek medical attention if you experience physical symptoms that can be related to over exposure to vibrations. Examples of such symptoms are numbness, lack of feeling, “tickling“, “pricking“, pain lack of or a reduction in normal strength, changes in the colour of the skin or its surfaces. These symptoms normally appear in the fingers, hands or wrists.

Cutting technique

The technique described below is of a general character.

1. Support the work piece in such a way that you can predict what will happen and so it will not pinch.
2. Always cut at full throttle.
3. Start cutting gently, do not force or squeeze the chain in.
4. Use a high chain speed.
5. Move the chain slowly backwards and forwards.

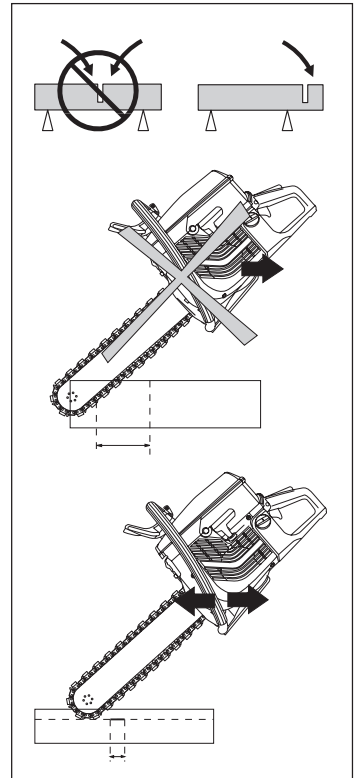

WARNING!
Under all circumstances avoid cutting using the side of the chain; it will almost certainly be damaged, break and can cause immense damage. Only use the cutting section.



WARNING!
Do not lean the saw to the side, this can cause the chain to jam or break with personal injury as a consequence.

SAFETY INSTRUCTIONS

Safety

Plan the work so that you do not get crushed by the bar when the pieces fall apart. Planning is also extremely important for your own safety! As it is usually a question of large and heavy pieces that are cut when using the diamond chain saw the forces are so great that jamming can result in irreparable damage to both the bar and chain.

You must plan before you start to cut how to support the workpiece according to how the pieces separate once cutting has been completed. In those cases where it is difficult to calculate how the pieces will fall apart, or when it is impossible to support the workpiece as you would like, wedging in the cut slot is a good and safe method.

Cutting holes

A common task for the diamond chain saw is making small openings in thick walls.

The order in which the cuts are made is probably obvious, but it should be pointed out: Start with the lowest cut followed by the sides and finish with the uppermost cut. The risk of jamming is then avoided.

Bracing

When cutting out large holes it is important that the piece to be cut out is braced so that it cannot fall against the operator.

Methods will naturally vary according to circumstances. One way is to drill a hole in the piece to be cut out and then bolt planks on both sides.

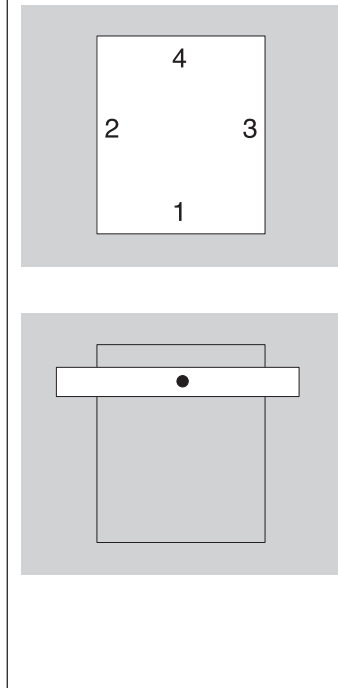
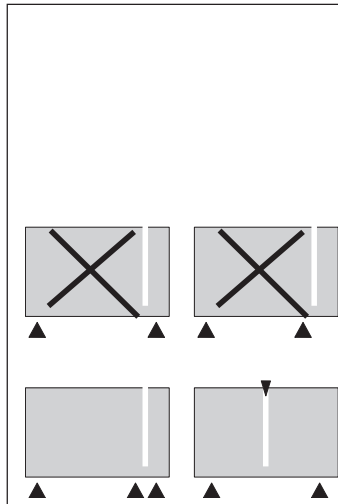

Efficient cutting

In principle there are two ways to start the process of entering a thick object to be cut.

Plunge-cut method

Start by making a 10 centimetre deep cut in the wall using the lower part of the tip of the bar. Straighten up the saw at the same time as the tip of the bar is inserted in the slot. Raising and lowering the saw at the same time as it is pressed into the wall provides an effective method of cutting to the full depth.

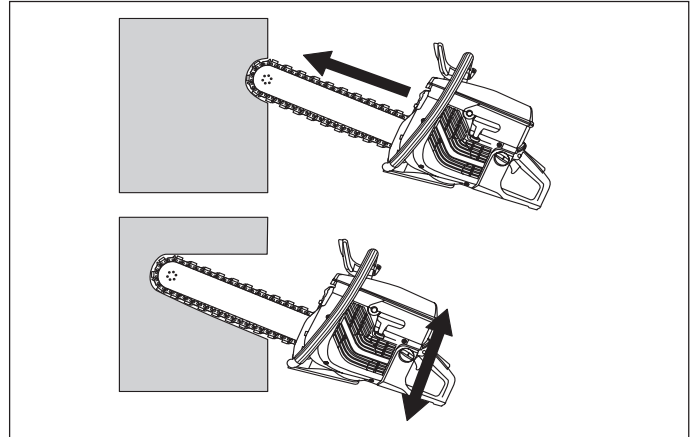

Pilot method

This method is recommended when attempting to cut absolutely straight and square.



WARNING!

Never use a power cutter with a standard cutting blade for pilot cutting. The cutting blade produces a pilot slot that is too thin and continued cutting with the diamond chain saw results infallibly in dangerous kickback and jamming in the slot.

It is appropriate to start by securing a board where the cut is to be made. This serves as a guide for the cut. Cut to a depth of a few centimetres along the entire line, using the lower section of the tip of the bar. Go back and cut another few centimetres. Repeat until a depth of between 5–10 centimetres is reached, depending on precision demands and the thickness of the object. The pilot cut guides the bar straight during continued cutting, which takes place according to the plunge-cut method until full depth is reached, use a rubber block as a break point/stop.

Pendulum technique

The entire cut is then made using a pendulum motion and the saw is only held straight at the ends of the cut.

Generally you should attempt to get the chain to cut over distances that are as small as possible. The partial pressure will then be higher and the cutting process will then be faster.

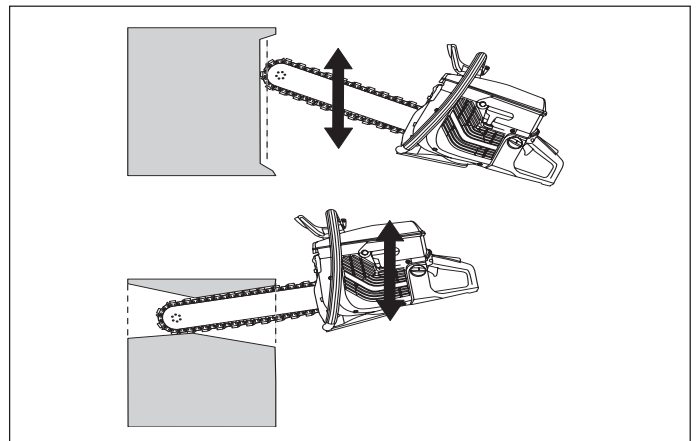

SAFETY INSTRUCTIONS

Water cooling



WARNING! Water cooling is only used on petrol driven diamond chain saws when cutting concrete to cool the chain and increases its service life as well as reducing dust (see the section "Cutting equipment"). Among the disadvantages are difficulties at very low temperatures, the risk of damaging the floor and other sections of the building and risk for slippage.

Sharpening diamond chains

Chains can become dull when the wrong feeding pressure is used or when cutting some materials such as heavily reinforced concrete. To force a dull chain results in overheating and finally the loss of segments (part of the chain).

Sharpen against a soft abrasive material such as sandstone or brick.

Chain vibration

Excessive vibration can occur if a too high feeding pressure is used or if the chain is pressed into the work piece.

A lower feeding pressure ought to stop the vibration. Otherwise replace the cutting chain.

Kickback



WARNING! Kickback can occur very suddenly and with great force. If the following directives are not followed, it can result in serious or even fatal injury.

If the sector of the chain illustrated below is used for cutting the chain can start to climbing and kickback the cut-off saw upwards and backwards towards the user with immense force.

How to avoid kickback

1. Never cut with the segment illustrated in the diagram.
2. Keep a good balance and a firm foothold.
3. Use both hands and take a firm grip with the thumb and fingers around the handle.
4. Keep the work piece at a comfortable distance.
5. Use the cutter at full throttle.
6. Take care when inserting the chain in an existing cut.
7. Never cut above shoulder height.
8. Be alert to movement of the work piece or anything else that can occur, which could cause the cut to close and pinch the chain.

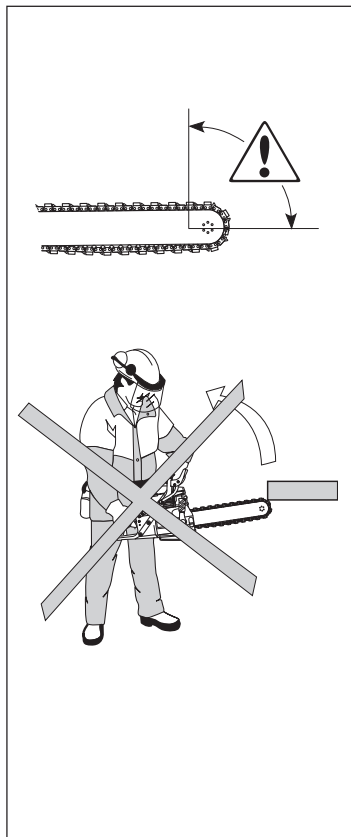

Pull in

Pull in occurs when the lower part of the chain is suddenly stopped or when the cut closes. (To avoid this see the section "How to avoid kickback" and "Pinching/rotation" below).

Pinching/rotation

Pinching occurs when the cut closes. The cut-off saw can be drawn suddenly and powerfully downwards.

How to avoid pinching

Support the work piece in such a way that the cut remains open during the cutting operation and when the cut is finished.

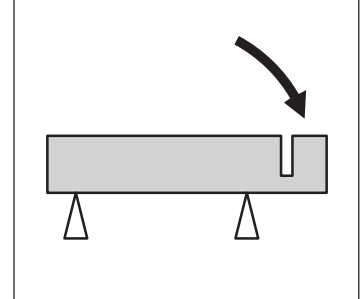

WARNING! If the speed is higher than that stated then the unit must be adjusted by an authorised service workshop before it is used.

Care and storage

General

Husqvarna's cut-off saws are robust and durable. However, as they are used for high speed operations all servicing should be carried out on time and as specified, so that the cut-off saw always works effectively and safely.

Read this Operator's Manual to determine which service routines you can carry out and ensure that all other service work is carried out by an authorised service workshop.

Always handle the cut-off saw with care and store it with the cutting equipment removed.

Cutting equipment

- The cutting equipment should be removed from the cutter after use and stored carefully.
- Inspect new cutting equipment for transport or storage damage.

Once the work has been completed the diamond chain saw should be run with water pressure for at least 15 seconds to clean particles from the bar, chain and drive mechanism. Rinse off the machine with water.

It is recommended that the chain and bar are oiled to prevent corrosion if it is not to be used for some time.

SAFETY INSTRUCTIONS

CUTTING EQUIPMENT

CAUTION! Chain breakage can result in serious injury if the chain is thrown towards the operator.

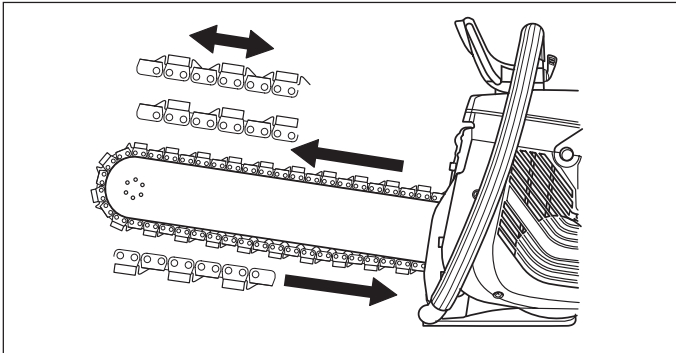

Diamond chains

There are two basic types of diamond chain available on the market. The difference between these is whether the chain has rakers on just one side of the diamond segment or on both sides. When using a chain with one raker, the chain should always be fitted the right way round, i.e. the raker should guide the segment at the right height in the cut. When using a chain with double rakers, the chain can be fitted either way round.

CAUTION! If the chain has been used and is refitted it must be fitted in the same working direction as earlier in order to reduce segment wear and to obtain full cutting capacity directly.

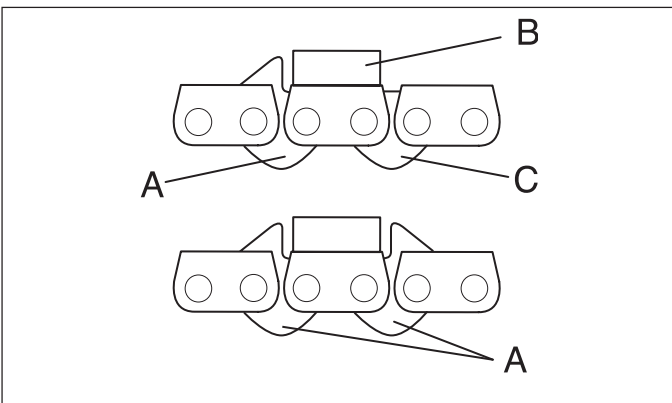

- A) Drive link with raker
- B) Cutting link with diamond segment
- C) Drive link

Check the chain

Check that the chain does not show signs of damage in the form of play on the links, broken raker or drive links or broken segments.

If the chain has been exposed to hard jamming or other abnormal overloading, the chain should be dismantled from the bar for careful inspection.

Fit the chain the right way round

The chain must never be fitted the wrong way round. The raker should guide the segment at the right height in the cut.

Check the saw

The saw is equipped with a number of safety features that protect the operator in the event of chain breakage. These safety features must be checked before work starts. Never use the saw if any of the following parts are damaged or missing:

- Cover over drive gear
- Damaged or missing hand guard
- Damaged chain

Use the saw the right way up

For reasons of safety the saw must never be used upside down. Parts worn loose from the cut object or damaged chain parts can be thrown towards the operator.

Do not cut any material other than what the machine is intended for

The diamond chain saw is only intended for cutting concrete, stone, brick and similar material. The saw must never be used to cut pure metals – this will probably result in broken segments or chain breakage. The diamond segment can cut reinforced concrete. Try to cut the reinforcement together with as much concrete as possible, this will save the chain.

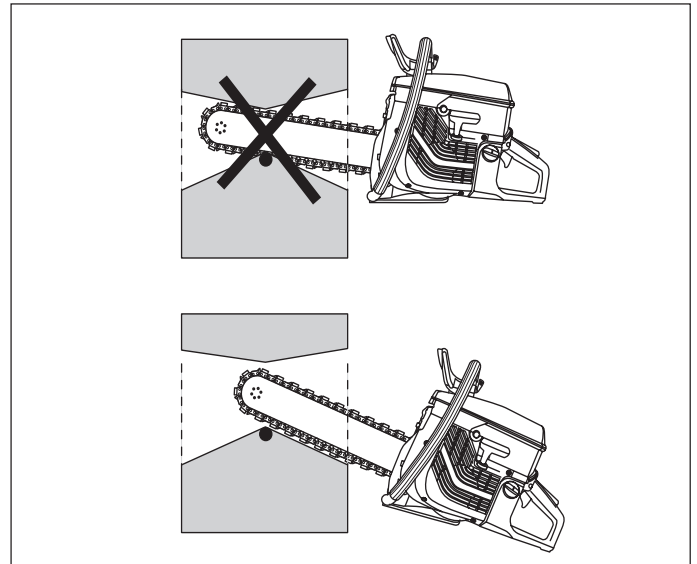

Glazing

After cutting extremely hard concrete or stone the diamond segment may lose some or all of its cutting capacity. This can also occur if you are forced to cut with a low partial pressure (the diamond chain runs against the workpiece along the entire length of the bar). The solution to the problem is to cut in a soft abrasive material such as sandstone or brick, for a short while.



WARNING!
Under no circumstances may the diamond chain saw be converted to cut other materials than those it is intended for. It must never be equipped with a timber saw chain.

WHAT IS WHAT?

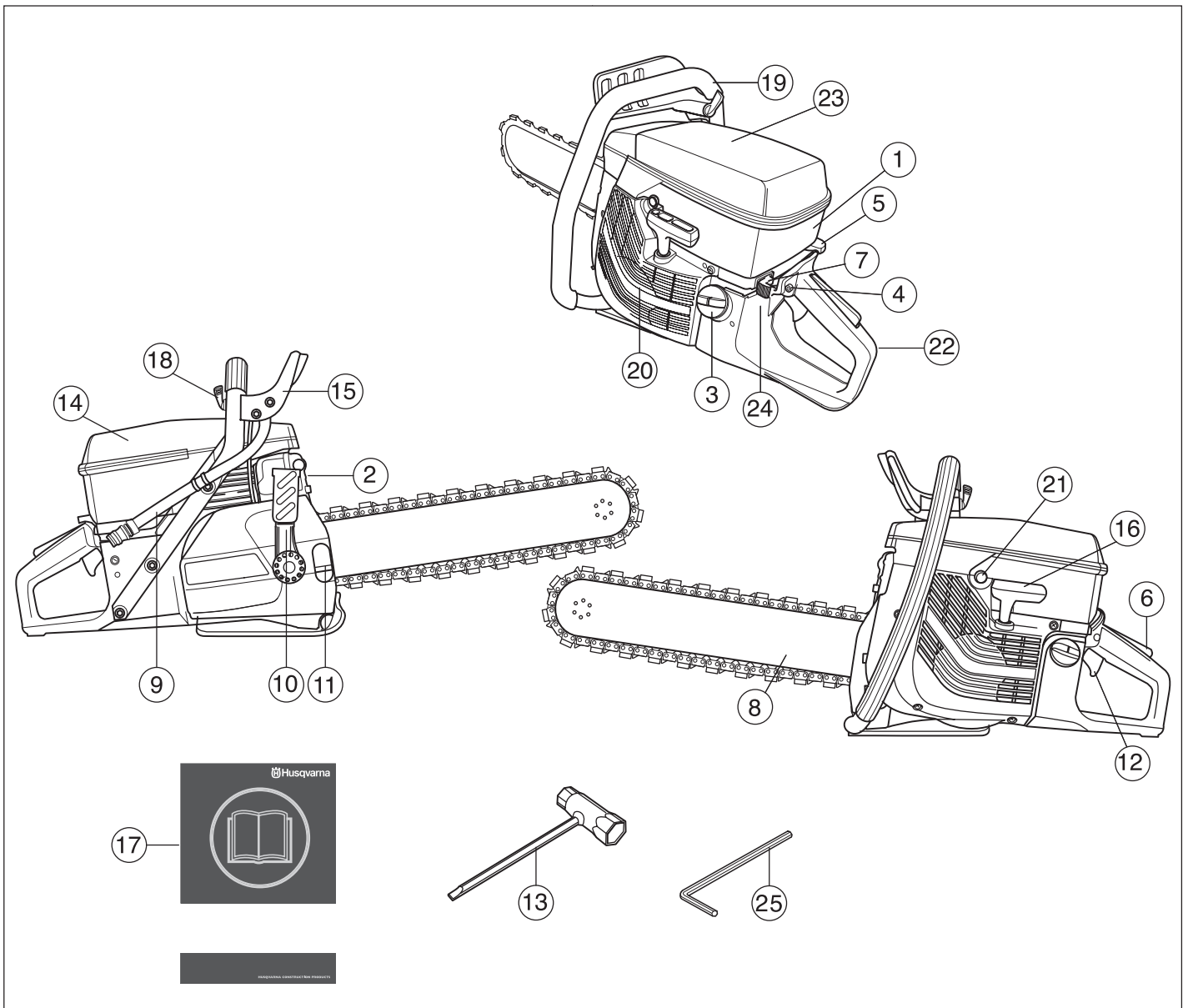

What is what on the machine?

- | | |
|---------------------------------|----------------------------|
| 1. Cylinder cover | 14. Air filter cover |
| 2. Muffler | 15. Hand guard |
| 3. Fuel tank | 16. Starter handle |
| 4. Starter throttle catch | 17. Operator's manual |
| 5. Choke | 18. Water adjustment valve |
| 6. Throttle trigger lockout | 19. Front handle |
| 7. Stop switch | 20. Starter |
| 8. Bar and chain | 21. Decompression valve |
| 9. Water hose, quick connection | 22. Rear handle |
| 10. Chain tensioning handle | 23. Warning decal |
| 11. Counter screw | 24. Type plate |
| 12. Throttle control | 25. Allen key |
| 13. Combination spanner | |

ASSEMBLY

How to tension the chain

Untensioned chain.

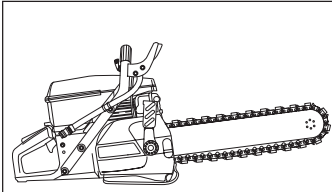

Start with opening the adjust screw cover.

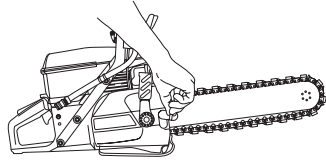

Pull the handle backwards.

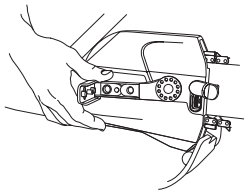

Continue to move the handle down-wards until you start to tension the chain.

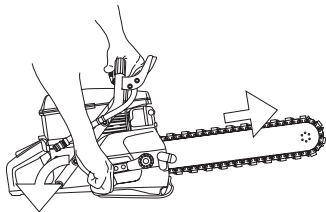
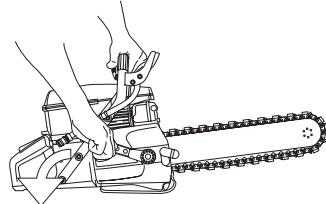

Hold the bar upwards as you move the handle forward.

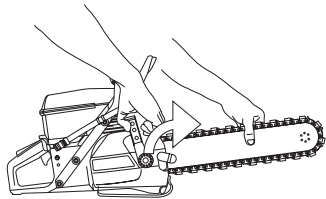

Tighten the adjust screw.

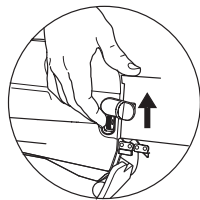

Close the adjust screw cover.

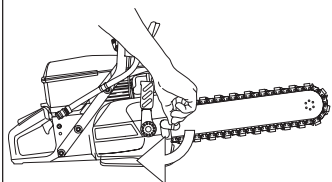

How to change the chain and rim

Press the spring down into the chain tensioner handle and turn the nut anti-clockwise.

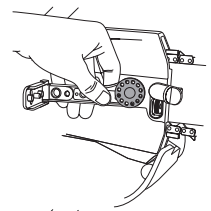

Unscrew the adjusting nut.

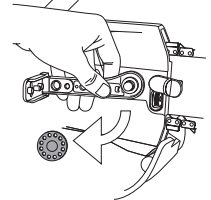

Remove the cover.

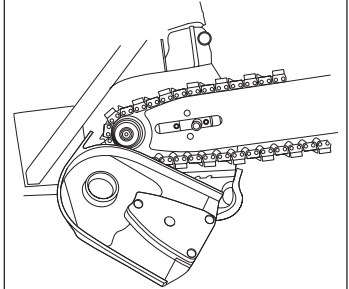

Remove the bar and chain.

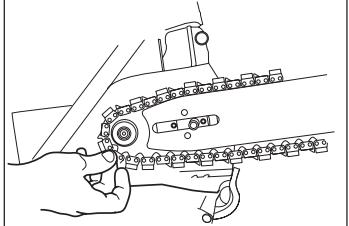

Remove the spring holding the two "half-moons" using a screwdriver.

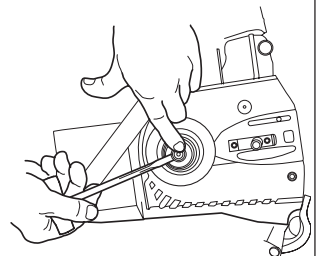

Remove the "half-moons", the cup and rim.

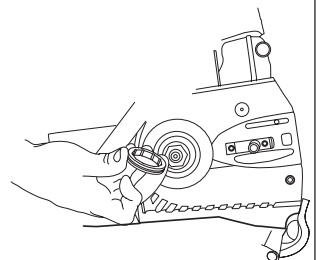

Remove the drive wheel.

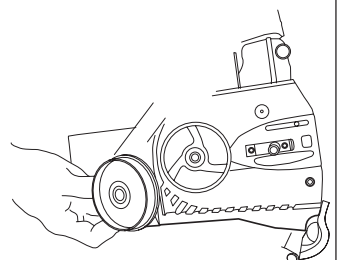

Assembly takes place in the reverse order.

ASSEMBLY

How to change the clamping force of the bar

Check whether the handle feels loose.

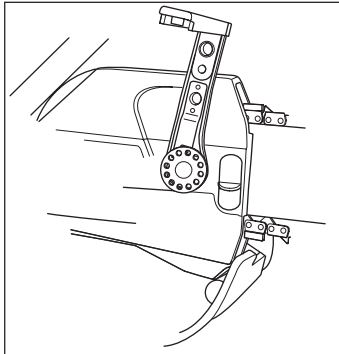

Move the lever to its rear, lower position. Press in the lever's spring and turn the adjusting nut clockwise.

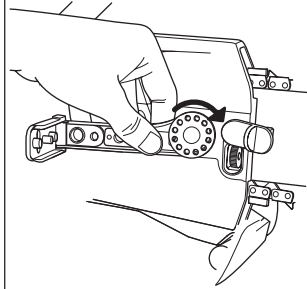

After adjustment, the chain tensioner handle should point nearly straight up (see figure) when it is moved as far as possible clockwise.

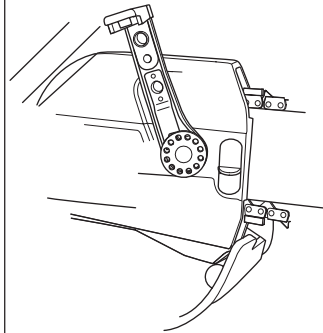

NOTICE! During all reassembling, make sure that the outer cover fits in to the inner cover, the covers may be damaged otherwise.

FUEL HANDLING

Fuelmix

IMPORTANT! The machine is equipped with a two-stroke engine and must always be run using a mixture of gasoline and two-stroke engine oil. It is important to accurately measure the amount of oil to be mixed to ensure that the correct mixture is obtained. When mixing small amounts of fuel, even small inaccuracies can drastically affect the ratio of the mixture.



Always provide for good ventilation when handling fuel.

Petrol

- Use good quality unleaded or leaded petrol.
- The lowest octane recommended is 90 (RON). If you run the engine on a lower octane grade than 90 so-called knocking can occur. This gives rise to a high engine temperature, which can result in serious engine damage

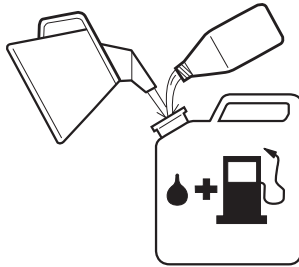

Two-stroke oil

- For best results and performance use HUSQVARNA two-stroke engine oil, which is specially formulated for our air-cooled two-stroke engines.
- Never use two-stroke oil intended for water-cooled engines, sometimes referred to as outboard oil (rated TCW).
- Never use oil intended for four-stroke engines.

Gasolin Benzin Essence Gasolina Lit.	Oil • Öl Huile • Aceite Lit.	
	2% (1:50)	3% (1:33)
5	0,10	0,15
10	0,20	0,30
15	0,30	0,45
20	0,40	0,60
US gallon	US fl. oz.	
	2% (1:50)	3% (1:33)
1	2 1/2	3 3/4
2 1/2	6 1/2	9 3/4
5	12 7/8	19 1/4

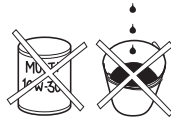

Mixing ratio

1:50 (2%) with HUSQVARNA two-stroke oil or equivalent.
1:33 (3%) with oils class JASO FB or ISO EGB formulated for air-cooled, two-stroke engines.

Mixing

- Always mix the petrol and oil in a clean container intended for fuel.
- Always start by filling half the amount of the petrol to be used. Then add the entire amount of oil. Mix (shake) the fuel mixture. Add the remaining amount of petrol.
- Mix (shake) the fuel mixture thoroughly before filling the saw's fuel tank.
- Do not mix more than max. one month's supply of fuel.
- If the cut-off saw is not used for some time the fuel tank should be emptied and cleaned.

Fuelling



WARNING! The following precautions reduce the risk of fire:

- Do not smoke or place any sources of heat in the vicinity of the fuel.
- Never refuel when the engine is running.
- Open the fuel cap slowly when fuelling so that any over pressure is released slowly.
- Tighten the fuel cap carefully after refuelling.
- Always move the machine from the fuelling place before starting.

- Keep the handle dry, clean and free from oil and fuel.

- Clean around the fuel cap. Clean the fuel tank regularly. The fuel filter should be changed at least once per year. Contamination in the tank can disrupt operations. Ensure that the fuel is well mixed by shaking the container before filling the tank.

- Always exercise care when filling the fuel. Move the cut-off saw at least three metres from the filling area before starting. Make sure the fuel cap is tightened.

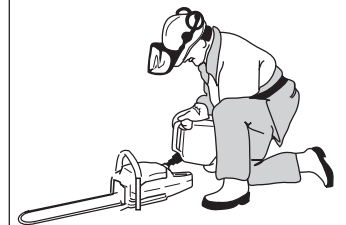
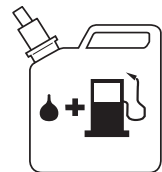
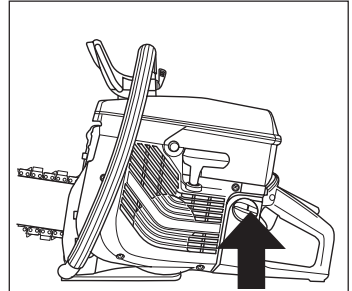

Min 3 m
(10ft)

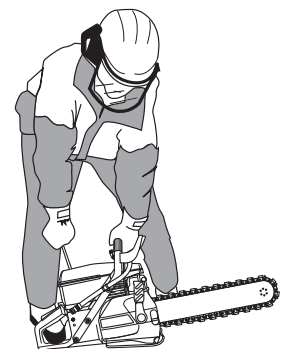

START AND STOP

Start and stop



WARNING! Before starting observe the following:

- Do not start the cut-off saw without the guide bar, chain and side cover fitted. Otherwise the clutch can come loose and cause personal injury.
- Always move the cut-off saw from the filling area before starting.
- Ensure that you and the machine stand firmly and that the cutting chain can rotate freely.
- Make sure no unauthorised persons are within the working area.

Starting a cold engine

IGNITION:

Slide the stop switch to the left.

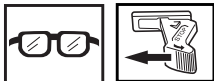

CHOKE:

Pull out the choke.



STARTER THROTTLE CATCH

Press in the throttle control and thereafter the starter throttle catch (A). Release the throttle control and the throttle is blocked in half throttle position. The catch is released when the throttle control is pressed in all the way.

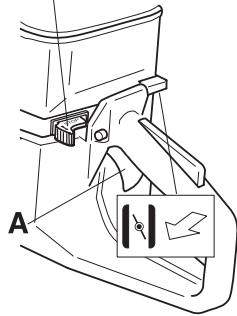

DECOMPRESSION VALVE

Press in the valve to reduce the pressure in the cylinder, this makes starting the cut-off saw easier. The decompression valve should always be used when starting. When the machine has started the valve automatically returns to its original position.

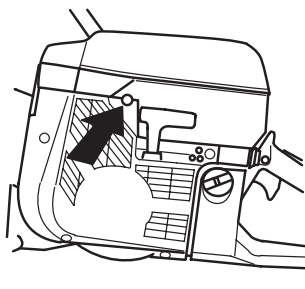

Starting a warm engine

Use the same procedure as for starting cold engine but without choke.

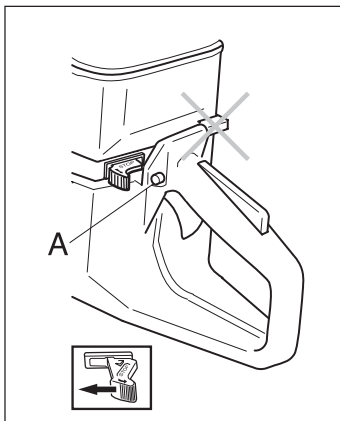

Wet cutting

The diamond chain saw must always be run with water cooling. Dry cutting causes immediate overheating and bar and chain failure with a risk of personal injury. In addition to cooling the bar and chain, the flow of water pushes particles away from the bar and the drive links. As a result it is important with a high water pressure. The water pressure should be at least 2.5 bar and a maximum of 11 bar. The recommended pressure is approx. 5 bar.

Start



WARNING! The cutting chain can rotate when the engine starts. Make sure it can rotate freely.

Take hold of the front handle using your left hand. Place your right foot on the lower section of the rear handle and press the cut-off saw against the ground. **Never twist the starter cord around your hand.**

Grip the starter with your right hand, and slowly pull the starter cord out until you feel some resistance (the pawls grip) now pull quickly and powerfully.

NOTE! Do not pull out the starter cord completely and do not release the starter from the fully extended position. This can damage the cut-off saw.

When the engine starts, quickly apply full throttle and the starter throttle catch will automatically disengage.

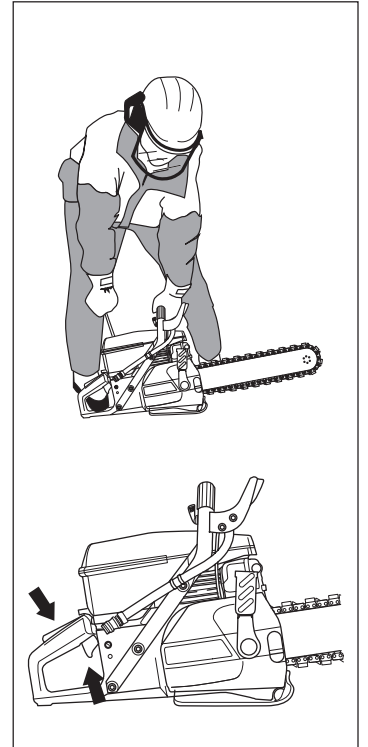

Stop

The engine is stopped by switching off the ignition. (Slide the stop switch to the right.)

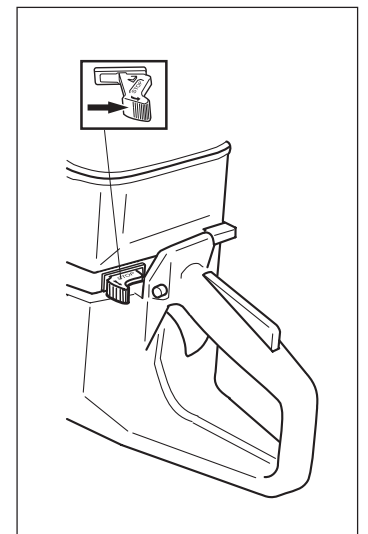

MAINTENANCE

Carburetor

Your Husqvarna product has been designed and manufactured to specifications that reduce harmful emissions.

After your unit has been run 8-10 tanks of fuel the engine has broken in. To ensure that your unit is at peak performance and producing the least amount of harmful emissions after break in, have your authorized servicing dealer, who has a revolution counter at his disposal, to check your carburetor for optimum operating conditions.

Functioning, Final setting



WARNING! Do not start the cut-off saw without the bar, chain and cover fitted. Otherwise the clutch can come loose and cause personal injury.

Operation

- The carburetor governs the engine speed via the throttle. Air/fuel are mixed in the carburetor

Jets

The carburetor is equipped with fixed jets to ensure the engine always receives the correct fuel air mixture.

If the engine lacks power or accelerates poorly do the following:

- Inspect or, if necessary, replace the air filter.
- If this does not help, contact an authorised service workshop.

Final setting of the idling speed T

Adjust the idling speed with the screw T. If it is necessary to re-adjust, first turn the idle speed adjusting screw T clockwise, until the chain starts to rotate. Then turn, counter-clockwise until the chain stops. A correctly adjusted idle speed setting occurs when the engine runs smoothly in every position. It should also be good margin to the rpm when the chain starts to rotate.

Recommended idling speed: 2 500 rpm.



Contact your servicing dealer, if the idle speed setting cannot be adjusted so that the chain stops. Do not use the cut-off saw until it has been properly adjusted or repaired.

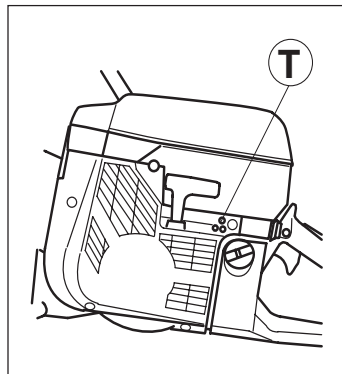

Fuel filter

- The fuel filter sits inside the fuel tank.
- The fuel tank must be protected from contamination when filling. This reduces the risk of operating disturbances caused by blockage of the fuel filter.
- The filter cannot be cleaned but must be replaced with a new filter when it blocked. **The filter should be changed at least once per year.**

Air filter

The air filter should be cleaned regularly removing dust and dirt to avoid:

- Carburettor malfunction
- Starting problems
- Reduced engine power
- Unnecessary wear to engine parts
- Abnormal fuel consumption



The air filter system consists of a main filter and a back-up filter:

1) The main-filter is an oiled foam filter that is easily accessible under the filter cover A. When used in dusty conditions, this filter should be checked/ replaced after every second tank of fuel. The filter must be cleaned and oiled regularly to obtain a satisfactory filtering effect. There is a special HUSQVARNA oil produced for this purpose.

- Remove the filter. Wash the filter carefully in tepid, soapy water. After cleaning rinse the filter thoroughly in clean water. Squeeze out the filter and let the filter dry. **NOTE!** Compressed air at a high pressure can damage the foam.

- Oil the filter carefully. It is extremely important that the entire filter is saturated in oil.

2) The back-up filter is a paper filter and is accessible from under cover B. This filter should be changed/cleaned when the engine's output drops or after 1-2 weeks. The filter is cleaned by shaking or carefully using compressed air. Note the filter must not be washed!

A filter used for a long period of time can never be completely cleaned. Therefore all air filters must be replaced periodically with a new filter. **A damaged air filter must always be replaced.**

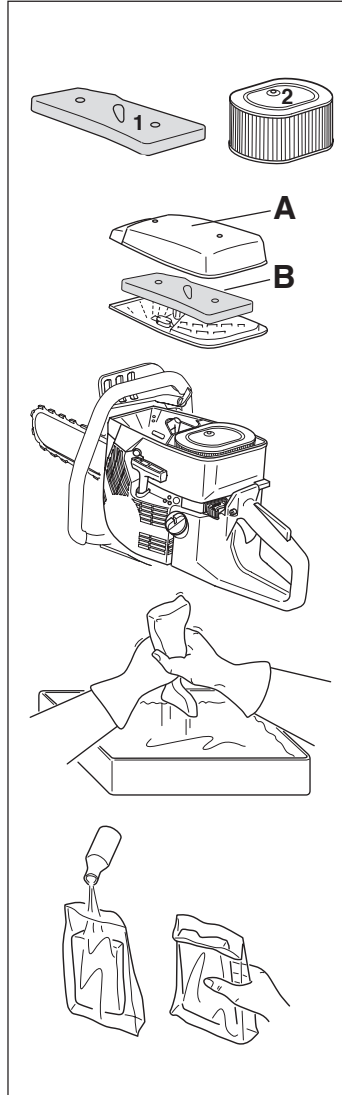

IMPORTANT INFORMATION!

Insufficient care of the air filter will cause deposits on the spark plug resulting in abnormal wear to engine parts.

MAINTENANCE

Starter



WARNING!

- The recoil spring sits in its tensioned position in the starter housing and can with careless handling fly out and cause personal injury.
- When replacing the recoil spring or the starter cord great care should be exercised. Always wear protective glasses.

Replacing a broken or worn starter cord



- Loosen the bolts that hold the starter against the crankcase and lift off the starter unit.
- Pull out the cord approx. 30 cm and lift it out of the cut-out in the starter-pulley's periphery. Reset the recoil spring by allowing the pulley to slowly rotate backwards.
- Loosen the screw in the centre of the starter-pulley and lift off the pulley. Insert and secure the starter cord in the starter pulley. Wind on approx. 3 turns of the cord on the pulley. Fit the pulley on the recoil spring so that the end of the recoil spring hooks on the pulley. Fit the screw in the centre of the pulley. Thread the starter cord through the hole in the starter housing and the starter handle. Tie a good knot on the end of the cord.

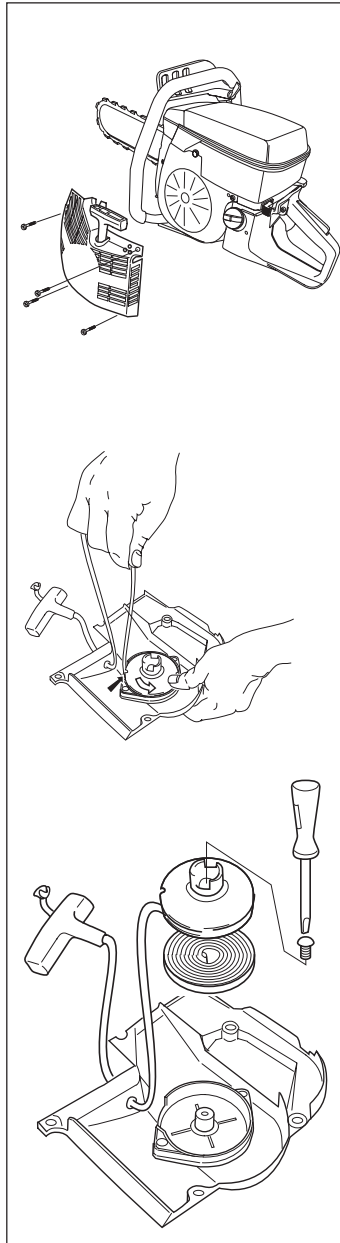

Tensioning the recoil spring

- Lift up the starter cord from the cut out on the pulley and turn the pulley approx. 2 turns clockwise.

NOTE! Ensure the starter pulley can be turned at least a further 1/2 turn when the starter cord is fully extended.

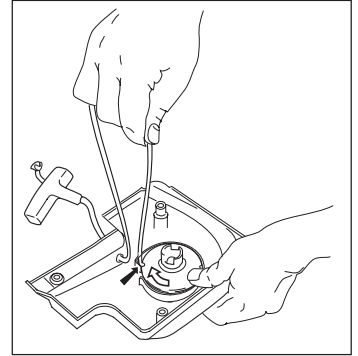

Replacing a broken recoil spring



- Lift the starter pulley (see "Changing a broken or worn starter cord").
- Loosen the screws holding the spring cassette.
- Disassemble the recoil spring by tapping the pulley (with its inside facing down) lightly against a working bench or similar. If the spring pops out when assembling, it should be mounted again, out and in towards the centre.
- Lubricate the recoil spring with thin oil. Assemble the starter pulley, and tension the recoil spring.

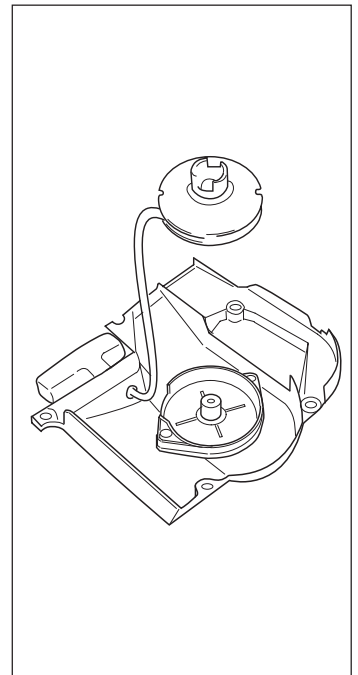

Fitting the starter

- Fit the starter by first pulling out the starter cord and then placing the starter in position on the crankcase. No slowly release the starter cord so that the pawls grip in the pulley.
- Fit and tighten the screws that hold the starter.

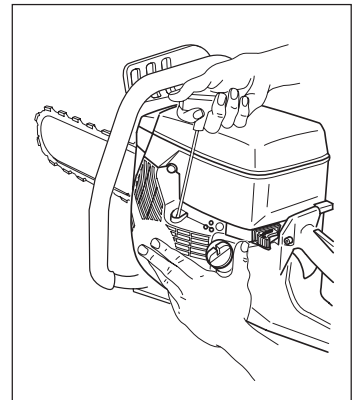

MAINTENANCE

Ignition system

IMPORTANT INFORMATION!

This cut-off saw has a green coloured ignition system with integrated speed governor (order no. 506 02 73-04). The machine may only be used with such a green coloured ignition system to prevent the risk of over revving.

Spark plug

The condition of the spark plug is affected by:

- An incorrect carburetor setting.
- An incorrect fuel mixture (too much oil).
- A dirty air filter.

These factors cause deposits on the spark plug electrode that may result in malfunction or starting difficulties.

- **If the machine is low on power, difficult to start or runs poorly while idling always check the spark plug first.** If the spark plug is dirty, clean it and at the same time check that the electrode gap is 0,5 mm (.020"). The spark plug should be changed after about one month of operation or earlier if necessary.

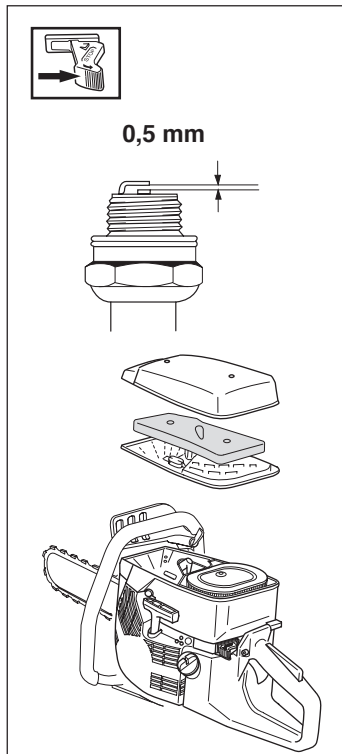

NOTE! Always use the recommended type of spark plug. (see chapter "Technical data")! An incorrect spark plug can damage the cylinder/piston.

Cooling system

To maintain as low an operating temperature as possible the cut-off saw is equipped with a cooling system.

The cooling system consists of:

1. An air intake on the starter unit.
2. Air flow guide.
3. Cooling fins on the flywheel.
4. Cooling fins on the cylinder.
5. Cylinder cover (leads cold air onto the cylinder).

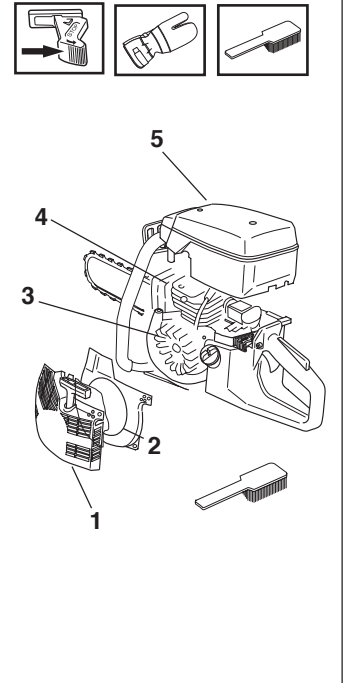

Clean the cooling system using a brush at least once a week, in difficult conditions more often. A dirty or blocked cooling system leads to the engine overheating resulting in damage to the cylinder and piston.

Muffler

The muffler is designed in order to reduce the noise level and to direct the exhaust gases away from the operator. The exhaust gases are hot and can contain sparks, which may cause fire if directed against dry and combustible material.

Never use a saw with a clogged or defective muffler.

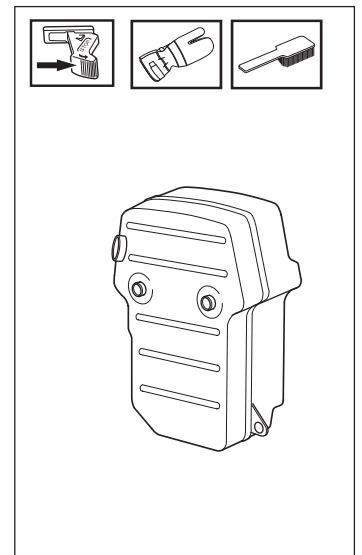

MAINTENANCE

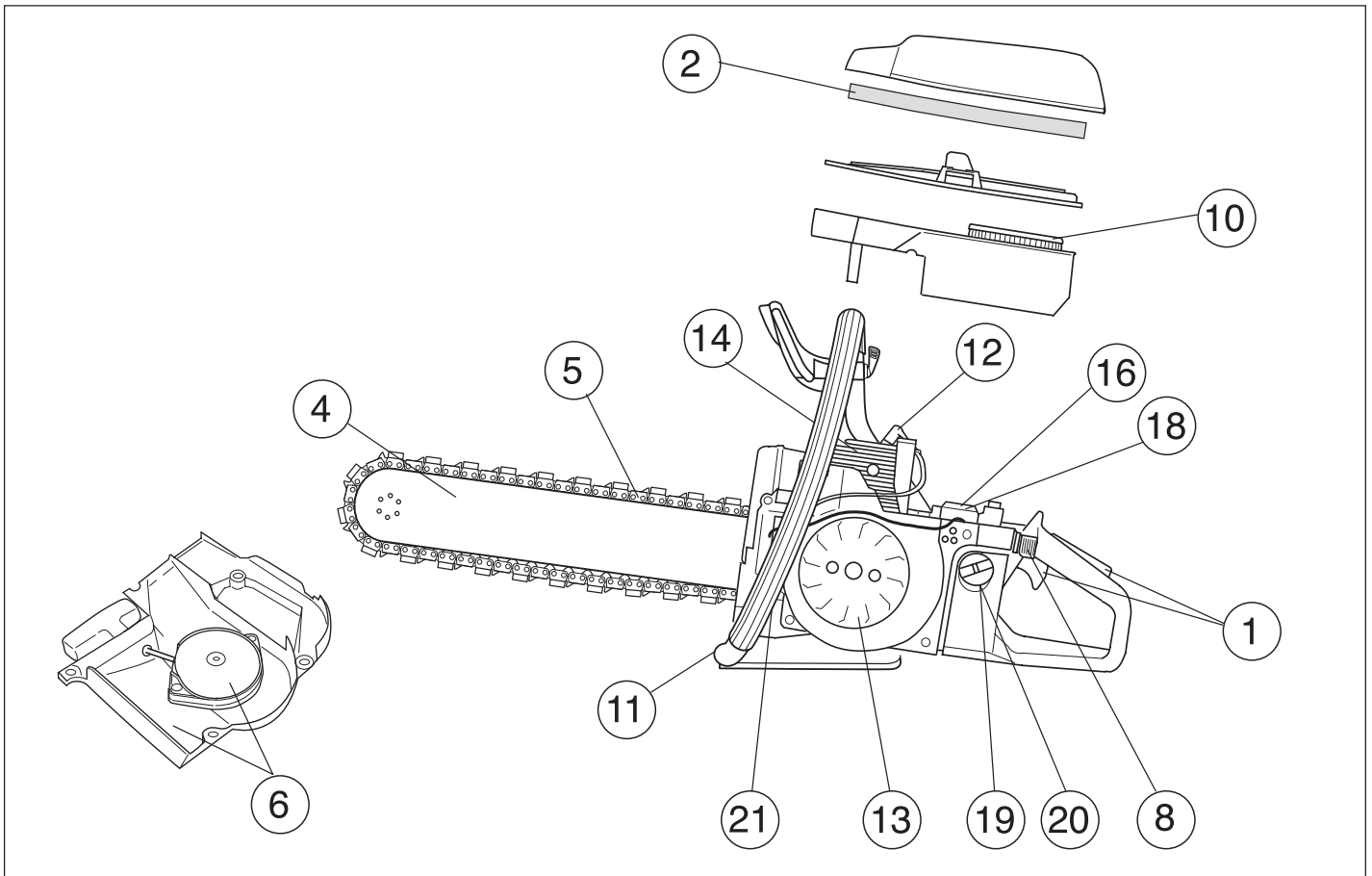

Below follows some general maintenance instructions. If you need further information please contact your service workshop.

Daily maintenance

1. Check that throttle components work correctly from a safety view point (throttle and starter throttle catch).
2. Clean the main filter.
3. Check the sprocket.
4. Check the condition of the bar.
5. Check the condition of the cutting chain.
6. Check the starter and the starter cord; clean the outside of the starter's air intake.
7. Check that all nuts and bolts are tightened correctly.
8. Check the function of the stop switch.
9. Lubricate the chain, bar tip sprocket and bar to avoid corrosion.

Weekly maintenance

10. Check the back-up paper filter.
11. Check that the handles and the anti-vibration elements are not damaged.
12. Clean the spark plug. Check that the electrode gap is 0.5 mm.
13. Clean the cooling fins on the flywheel. Check the starter and recoil spring.
14. Clean the cooling fins on the cylinder.
15. Check the muffler.
16. Check the carburetor function.

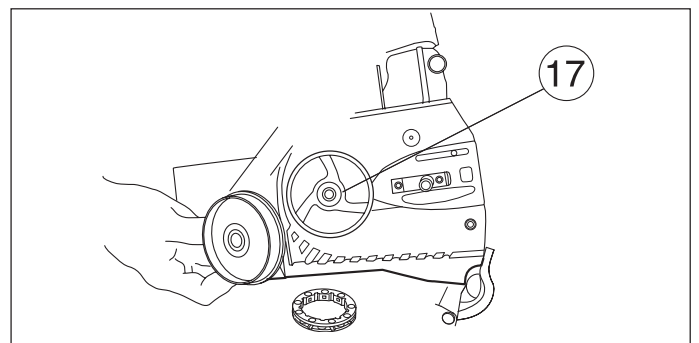
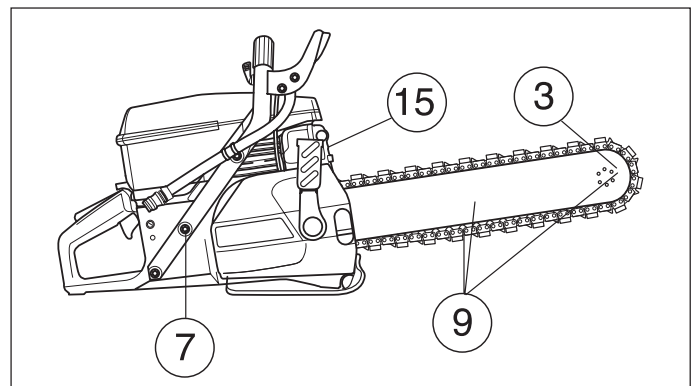

Monthly maintenance

17. Check the clutch drum and clutch springs with regard to wear.
18. Clean the outside of the carburetor
19. Check the fuel filter, fuel hose, change if necessary.
20. Clean the inside of the fuel tank.
21. Check all cables and connections.

TECHNICAL DATA

K950 Chain

Engine

Cylinder volume, cm ³ /cu.in	93,6/5,7
Cylinder bore, mm/inch	∅ 56/2,2"
Stroke, mm/inch	38/1,5"
Idle speed, rpm	2 500 rpm
Recommended max. speed, unloaded, rpm	9 750 ± 250
Power, kW	4,5

Ignition system

Manufacturer	FHP
Type of ignition system	CD
Spark plug	NGK BPMR 7A
Electrode gap, mm/inch	0,5 (.020")

Fuel and lubrication system

Manufacturer	Tillotson
Carburetor type	HS 282A
Fuel capacity, litre/US Pint	1,0/2,65

Weight

Without fuel and cutting equipment, kg/Lbs	9,4/20,7
--	----------

Noise emissions

(see note 1)

Sound power level, measured dB(A)	115
Sound power level, guaranteed L _{WA} dB(A)	116

Sound levels

(see note 2)

Equivalent sound pressure level at the user's ear, measured according to EN 1454 and ISO/DIS 11201, dB(A).	103
--	-----

Vibration levels

Handle vibrations measured according to ISO 19432

Front handle, equivalent value, m/s ²	4,6
Rear handle, equivalent value, m/s ²	9,3

Note 1: Noise emissions in the environment measured as sound power (L_{WA}) in conformity with EC directive 2000/14/EC.

Note 2: Equivalent sound pressure level is calculated as the time-weighted energy total for sound pressure levels under various working conditions with the following time distribution: 1/2 idling and 1/2 max speed.

Cutting equipment

Bar and chain	Max. speed
14"	28 m/s at 10 000 rpm



TECHNICAL DATA

EU declaration of conformity (Only applies to Europe)

Husqvarna Construction Products, SE-433 81 Partille, Sweden, tel: +46-31949000, declare under sole responsibility that the cut-off saw **Husqvarna K950 Chain** from 2006's serial numbers and onwards (the year is clearly stated in plain text on the type plate with subsequent serial number), are in conformity with the following standards or other normative documents following the provisions in the COUNCIL'S DIRECTIVES:

- of June 22 1998 "relating to machinery" **98/37/EC**, annex IIA.
 - of May 3 1989 "relating to electromagnetic compatibility" **89/336/EEC**, and applicable supplements.
 - of May 8, 2000 "relating to the emission of noise to surroundings" **2000/14/EC**. Conformity assessment according to Annex V.
- For information relating to noise emissions, see the chapter Technical data.

The following standards have been applied: **SS-EN ISO 12100:2003, EN-ISO 55012:2002, EN 1454, ISO 19432.**

SMP Svensk Maskinprovning AB, Fyrisborgsgatan 3, SE-754 50 Uppsala, Sweden, has carried out voluntary type approval concerning the directive 2000/14/EC on behalf of Husqvarna AB. The certificate is numbered: **01/169/012** – K950 Chain.

Partille November 14, 2006



Ove Donnerdal, Development Manager.

115 02 90-26



2006-12-18